

Shock Mounting

Type X-Mount



Type X shock mountings are highly effective in reducing the transmission of vibration, structure-borne noise and shock from a wide range of rotating and reciprocating machinery. Also in protecting sensitive apparatus from external disturbances.

Design Features

- Manufactured in stainless steel with high impact nylon washers for fixing bolts.
- Two different horizontal stiffness axes enable optimum system characteristics and vibration isolation to be achieved using careful orientation of the mountings.
- Each isolator is individually stencilled with nominal load on outer casing for easy identification.
- Static Deflections of up to 8 mm with loads from 6 kg to 450 kg.

Typical Applications

- Control Panels.
- Axial and Centrifugal Fans.
- Air Handling Units.
- Pumps and Compressors.
- Isolation of Sensitive Equipment.
- Electrical Cabinets/Panels.
- Transformers.

TYPE X-MOUNT SHOCK ISOLATORS

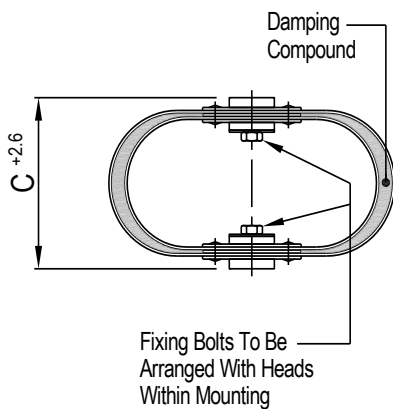

PART No.	NOM. LOAD (kg)	LOAD RANGE (kg)	DIMENSIONS (mm)						BOLT SIZE F	WT EACH (kg)	STIFFNESS (N/mm)		
			A	B	C		D	E			VERTICAL	LATERAL	
					LOADED	FREE						kz	kx
X.006	6	4 - 6	133.5	25	73	82	15	19	M8	0.14	5.91	3.25	7.68
X.010	10	9 - 18	203	51	107	114	23	32	M8	0.7	13	7	17
X.020	20	18 - 35			106	114							
X.045	45	35 - 55	216	51	124	133	26	32	M12	1.1	70	39	91
X.070	70	55 - 90			124	133							
X.110	110	90 - 135	297	102	185	190	43	64	M20	5.9	350	175	665
X.180	180	135 - 250			185	190							
X.320	320	250 - 380	297	102	186	190	43	64	M20	6.6	500	219	788
X.450	450	380 - 550			186	190							

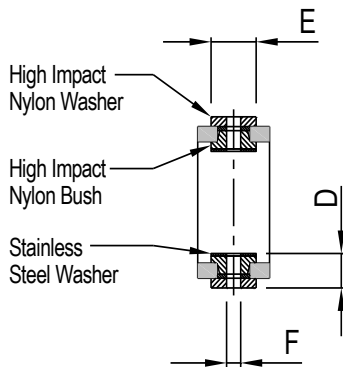
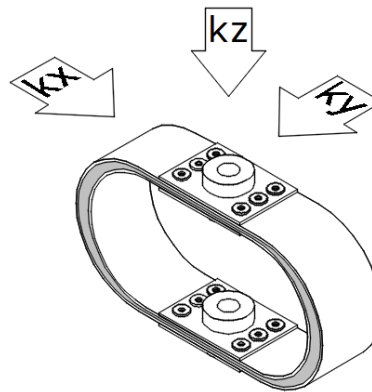
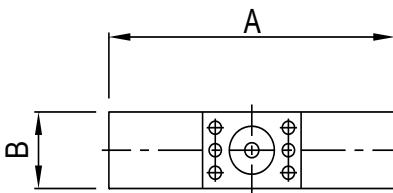

Application Notes:

- +2.6 mm allowable tolerance on dimension 'C' free height.
- Optimum system stiffness characteristics can be achieved by careful orientation of individual isolators.
- Optional soleplate is available to facilitate installation on resin chocks.
- We recommend that all fixing bolts used are high tensile Grade 8.8 or higher.
- All connections to and from isolated machine must include flexible lengths, not only to prevent transmission of vibration through the connections and allow the system freedom of movement, but also to avoid possible failure of the connections.

For full instructions please refer to our datasheets DS038

For more detailed information and technical assistance please contact our Technical Department.

In the interests of continual development, the Company reserve the right to make modifications to these details without notice.



Christie & Grey Ltd

Morley Road,
Tonbridge, Kent
TN9 1RA, England

T: +44 (0)1732 371100
E: sales@christiegrey.com
W: www.christiegrey.com



Christie & Grey
SINCE 1914