

Marine Rubber Turret Mountings

Type MRM



Design Features

- Moulded in first grade natural rubber with integral steel base and upper fixing boss.
- Available in three rubber compounds identified by a colour spot.
- Static deflections of up to 6 mm with loads from 5 kg to 80 kg.
- Turret mountings are supplied fixed to an aluminium base plate.
- Integral rebound unit incorporated to control movement due to ship motion.
- Low height compact unit, ideal for use where space is limited.

Typical Applications

- Axial and Centrifugal Fans.
- Air Handling Units.
- Refrigeration Plant.
- Pumps.
- Rotary and Multi Cylinder Compressors.
- Isolation of Sensitive Equipment.

Marine Rubber Turret mountings are designed to provide superior attenuation of medium to high frequency vibration and noise emanating from a wide range of motor driven machines particularly axial and centrifugal fans.

High resilience rubber with low dynamic to static stiffness ratio ensures maximum efficiency, good creep performance and long service life.



MARINE RUBBER TURRET MOUNTINGS

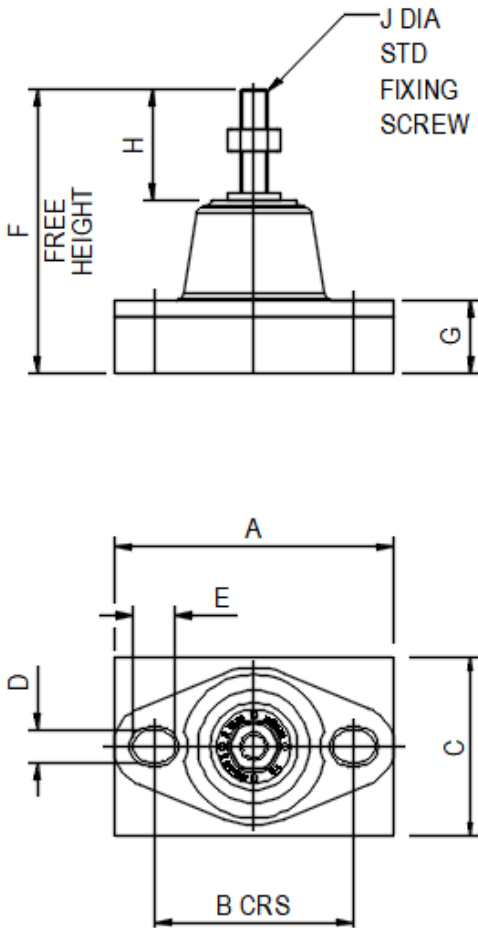

PART No.	COLOUR CODE	RATED LOAD (kg)	DEFLECTION AT RATED LOAD (mm)	DIMENSIONS (mm)								WT MAX (kg)	
				A	B	C	D	E	F	G	H		J
19.100.Y.M	YELLOW	28	6	80	57	51	9	12	80	21	30	M8	0.31
19.100.B.M	BLUE	50											
19.100.R.M	RED	80											

LOAD/DEFLECTION AND ISOLATION EFFICIENCY GRAPHS

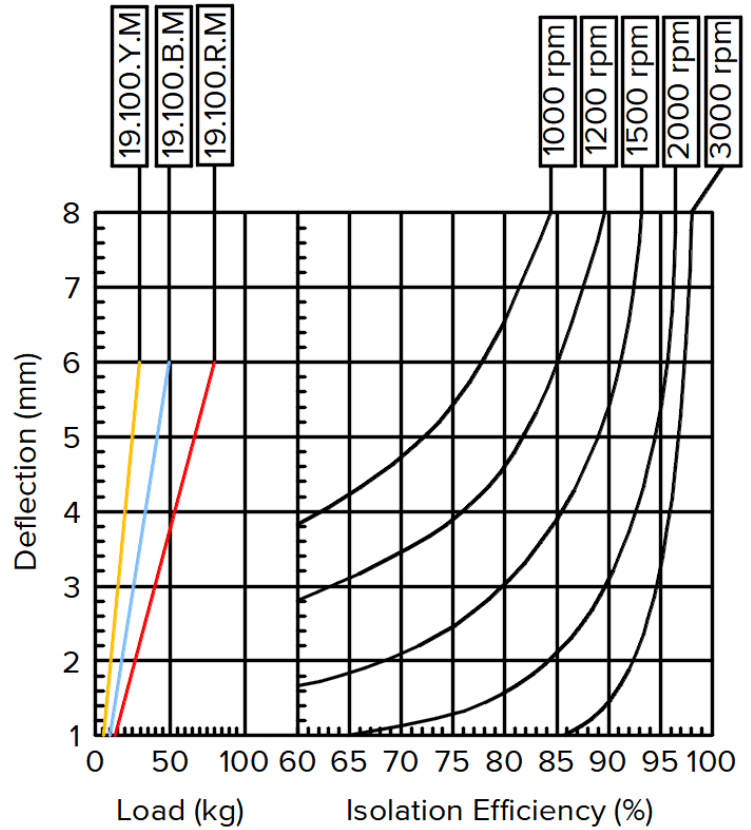

Isolation efficiency is based on dynamic rather than static stiffness for accurate calculation of system performance.

Application Note:

Rubber Turret mountings should not be used on machines exhibiting high out of balance forces.

For full instructions please refer to our datasheets DS010

For more detailed information and technical assistance please contact our Technical Department.

In the interests of continual development, the Company reserve the right to make modifications to these details without notice.



Christie & Grey Ltd

Morley Road,
Tonbridge, Kent
TN9 1RA, England

T: +44 (0)1732 371100
E: sales@christiegrey.com
W: www.christiegrey.com



Christie & Grey
SINCE 1914