

# Shock Mounting

Type FCR



Type FCR Shock Mountings are highly effective in reducing the transmission of vibration, structure borne noise and shock from a wide range of rotating and reciprocating machinery. Also in protecting sensitive apparatus from external disturbances.

## Design Features

- Inclined rubber springs are first grade rubber to metal bonded elements.
- SG iron castings to BS EN 1536:1997 EN-GJS-400/15.
- Rubber spring elements are effectively protected by the top casting and its extended skirt.
- Two different horizontal stiffness axis enable optimum system characteristics and vibration isolation to be achieved using careful orientation of the mountings.
- Static deflections of up to 30 mm with loads from 250 kg to 2200 kg.

## Typical Applications

- Diesel Generating Sets.
- Axial and Centrifugal Fans.
- Air Handling Units.
- Refrigeration Plant.
- Pumps and Compressors.
- Lift Motor Gear.



Central Hole Tapped  
for M20 Fixing Bolt

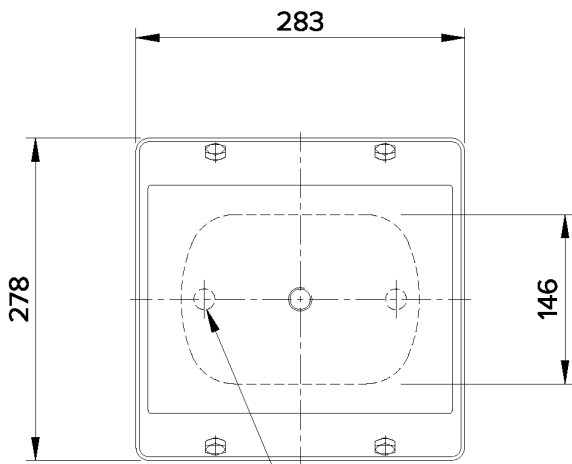
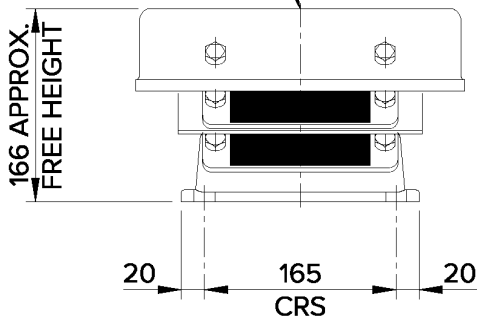

2 No. Holes for  
M16 H.D. Bolts

### TYPE FCR SHOCK ISOLATOR

PART No.	MAXIMUM LOAD (kg)	STATIC STIFFNESS (N/mm)			DYNAMIC / STATIC STIFFNESS RATIO	WEIGHT MAX (kg)
		kx	ky	kz		
FCR / 35	490	305	63	165	1.1	19.2
FCR / 45	670	445	102	225	1.15	
FCR / 55	1000	640	134	340	1.25	
FCR / 60	1280	910	200	430	1.35	
FCR / 65	1500	1090	220	495	1.6	
FCR / 70	1840	1360	275	620	1.7	
FCR / 75	2200	1780	375	900	1.9	

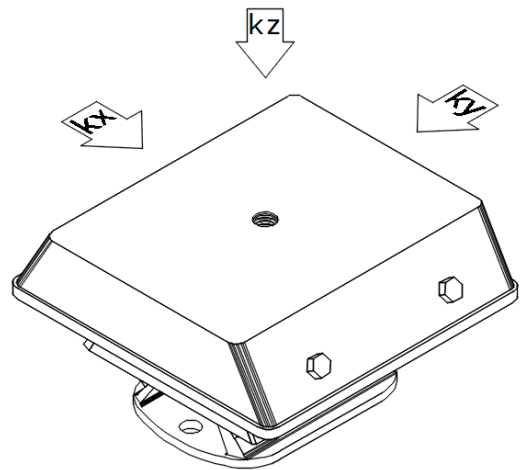

#### Important Notes

- All values of stiffness are nominal subject to  $\pm 20\%$  variation on final assembly.
- Dynamic stiffness may vary with frequency. Values stated are reliable for calculation of low frequency characteristics below 100 Hz.
- Optimum system stiffness characteristics can be achieved by careful orientation of individual isolators.
- Optional soleplate is available to facilitate installation on resin chocks.
- Optional soleplate is available to facilitate installation on resin chocks.
- We recommend that all fixing bolts used are high tensile Grade 8.8 or higher.
- All connections to and from isolated machine must include flexible lengths, not only to prevent transmission of vibration through the connections and allow the system freedom of movement, but also to avoid possible failure of the connections.

**For full instructions please refer to our datasheets DS040**

**For more detailed information and technical assistance please contact our Technical Department.**

In the interests of continual development, the Company reserve the right to make modifications to these details without notice.



**Christie & Grey Ltd**

Morley Road,  
Tonbridge, Kent  
TN9 1RA, England

T: +44 (0)1732 371100  
E: sales@christiegrey.com  
W: www.christiegrey.com



**Christie & Grey**  
SINCE 1914