

Rectangular

Type Sandwich Mounts



Rectangular mountings, also known as sandwich mountings, are widely used for mounting engines in road vehicles and mobile construction plant. In the larger sizes they are used as vehicle suspension springs and as mountings for acoustic chambers, hoppers and various types of heavy plant installation.

The rubber in the mountings is bonded between two metal plates with holes at each end for fitting. Some designs incorporate steel interleaves for increased load capacity. The mountings can be used in either shear or compression.

Design Features

- Moulded in first grade natural rubber.
- Steel metals, etch primed on external surfaces.
- Rectangular mountings should not be used in tension or exposed to contamination by mineral oils.

Typical Applications

- Lift Head Gear.
- Engine Mountings on Road Vehicles.
- Mobile Construction Plant.
- Hoppers.
- Heavy Plant.
- Conveyor Systems.



RECTANGULAR TYPE SANDWICH MOUNTS

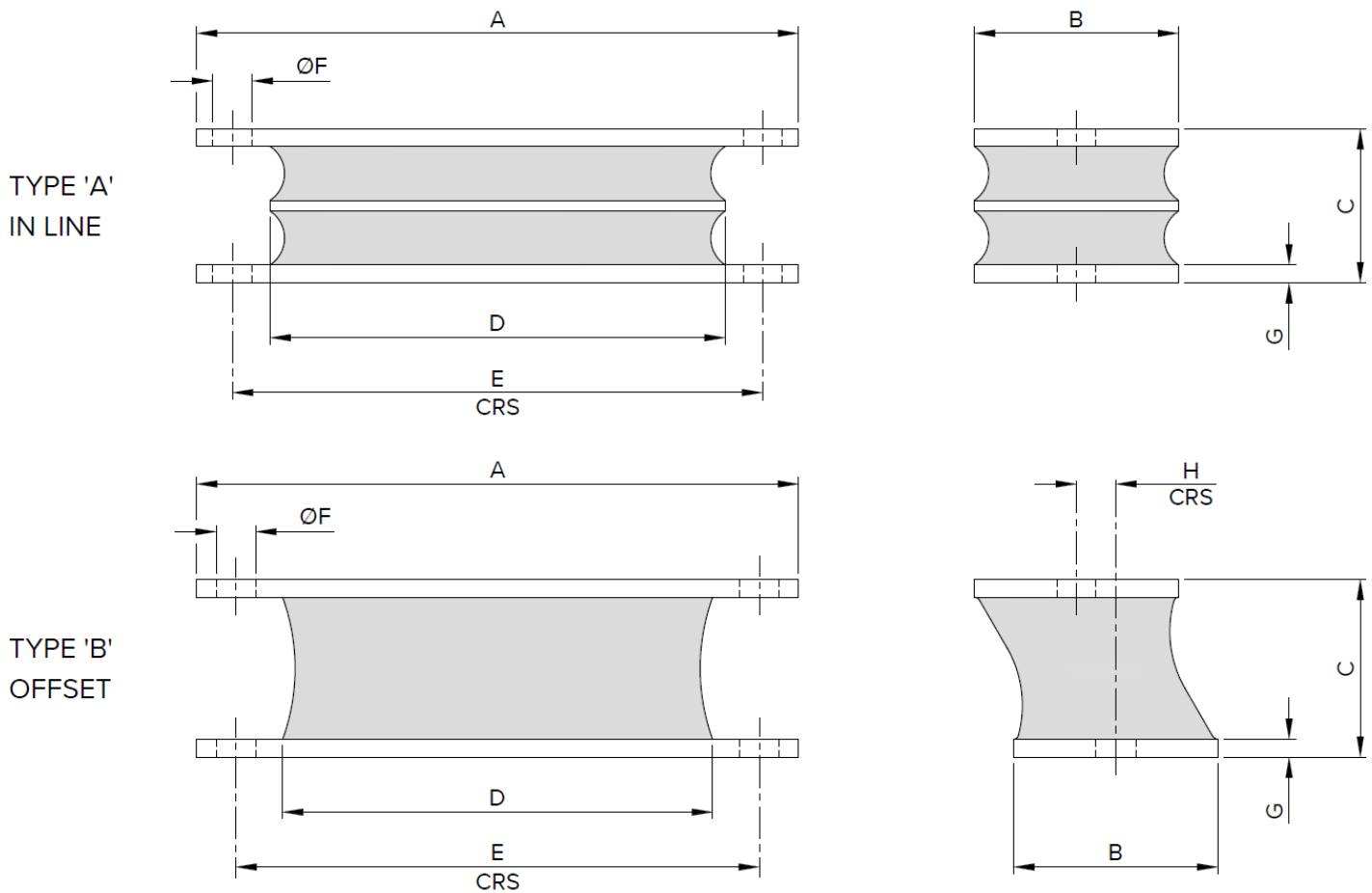

	PART No.	RUBBER SHORE HARDNESS	MAX LOAD / DEFLECTION				DIMENSIONS (mm)								STEEL INTERLEAF	WT MAX (kg)
			COMPRESSION		SHEAR		A	B	C	D	E	F	G	H		
			kg	mm	kg	mm										
TYPE 'A'	62.101	45	448	3.0	120	14.6	168	57	43	127	146	11	5	-	YES	1.2
		55	575	2.4	117	9.0										
		60	846	2.8	153	9.4										
		70	989	2.2	159	6.6										
	62.103	65	610	2.6	110	9.0	127	57	43	82	108	11	5	-	YES	0.8
TYPE 'B'	62.113	45	385	8.0	140	13.8	168	57	49.6	120	146	11	5	11	NO	1.0
		55	650	8.0	195	13.8										
		60	805	8.0	280	13.8										
		70	1220	7.0	365	12.0										

All parts are manufactured from first grade natural rubber with steel metals, etch primed on exposed surfaces.

Rectangular Sandwich Mounts should not be exposed to contamination by mineral oils.

Suffix part no. with .45, .55, .60 or .70 to indicate rubber hardness e.g. 62.101.60

For more detailed information and technical assistance please contact our Technical Department.

In the interests of continual development, the Company reserve the right to make modifications to these details without notice.



Christie & Grey Ltd
 Morley Road,
 Tonbridge, Kent
 TN9 1RA, England

T: +44 (0)1732 371100
 E: sales@christiegrey.com
 W: www.christiegrey.com

