

# Shock Mounting

## Type X – Mount



Type X shock mountings are highly effective in reducing the transmission of vibration, structure-borne noise and shock from a wide range of rotating and reciprocating machinery. Also in protecting sensitive apparatus from external disturbances.

### Design Features

- Manufactured in stainless steel with high impact nylon washers for fixing bolts.
- Two different horizontal stiffness axes enable optimum system characteristics and vibration isolation to be achieved using careful orientation of the mountings.
- Each isolator is individually stencilled with nominal load on outer casing for easy identification.
- Static deflections of up to 8 mm with loads from 6kg to 450 kg.

### Typical Applications

- Pumps and Compressors
- Isolation of sensitive equipment
- Electrical Cabinets/Panels
- Transformers

### TYPE X-MOUNT SHOCK ISOLATORS

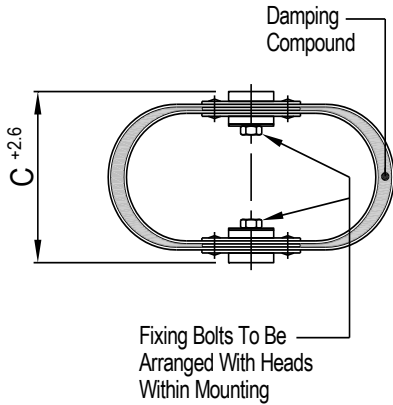

PART No.	NOM. LOAD (kg)	LOAD RANGE (kg)	DIMENSIONS (mm)					BOLT SIZE F	WT EACH (kg)	STIFFNESS (N/mm)			
			A	B	C		D			E	LATERAL		
					LOADED	FREE					kz	kx	ky
X.006	6	4.8 - 7.2	133.5	25	70	82	15	19	M8	0.14	5.91	3.25	7.68
X.010	10	9 - 15	203	51	106	114	23	32	M8	0.7	13	7	17
X.020	20	18 - 34									26	32	M12
X.045	45	34 - 54	216	51	124	133	26	32	M12	1.3	44	24	58
X.070	70	54 - 91									70	39	91
X.110	110	91 - 136									120	61	149
X.180	180	136 - 250	297	102	185	190	43	64	M20	5.9	350	175	665
X.320	320	250 - 386									500	219	788
X.450	450	386 - 545									875	385	1400

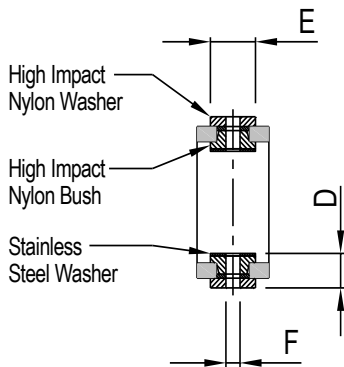
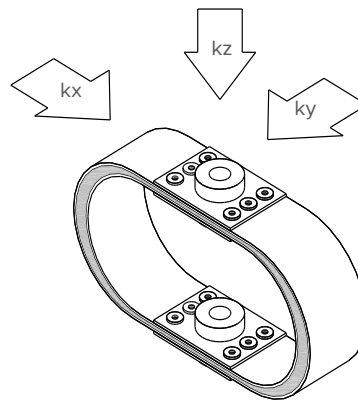
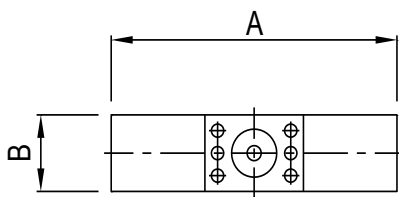

#### Application Notes

- +2.6 mm allowable tolerance on dimension 'C' free height.
- Optimum system stiffness characteristics can be achieved by careful orientation of individual isolators.
- Optional soleplate is available to facilitate installation on resin chocks.
- We recommend that all fixing used are high tensile Grade 8.8 or higher.
- For Bulkhead mounting, load capacity should be halved.
- All connections to and from isolated machine must include flexible lengths, not only to prevent transmission of vibration through the connections and allow the system freedom of movement, but also to avoid possible failure of the connections.

**For full instructions please refer to our data sheet DS038.**

**For more detailed information and technical assistance please contact our Technical Department.**

In the interests of continual development, the Company reserve's the right to make modifications to these details without notice.



**Christie & Grey Ltd**  
 Morley Road,  
 Tonbridge, Kent  
 TN9 1RA, England

T: +44 (0)1732 371100  
 E: sales@christiegrey.com  
 W: www.christiegrey.com



**Christie & Grey**  
 SINCE 1914