

# Enclosed Spring Mountings

Type ES - Enclosed Spring and ECS - Enclosed Captive Spring Mounting



A unique range of mountings designed primarily for building services applications where the control of low frequency vibration and noise emanating from mechanical plant is of paramount importance.

The benefits of a combined rubber and steel housing for the spring have helped establish the ES and ECS mountings as industry standards accepted by specifiers, equipment manufacturers and mechanical services installers alike.

## DESIGN FEATURES

- Nitrile rubber (oil resistant) lower spring housing eliminates the possibility of metallic continuity and ensures excellent acoustic performance. Steel reinforced on ECS range.
- Full enclosed captive assembly protects the spring and controls transient motion.
- All steel components are zinc plated.
- Nominal 15, 20, 25 & 50 mm deflection colour coded helical steel springs to BS1726 Class B, laterally stable with 50% overload capacity.
- Simple single screw height adjustment.
- 6 mm thick ribbed rubber seating pads available for ES25 and ECS ranges.
- Colour coded labels for easy identification.
- Stainless Steel variants available.

## TYPICAL APPLICATIONS

- Axial and Centrifugal Fans.
- Air Handling Units.
- Chillers and Cooling Towers.
- Rotary and Multi Cylinder Compressors.
- Diesel Generating Sets (ECS only).
- Mechanical Test Rigs.
- Isolation of Sensitive Equipment.

## TYPE ES, ESB, ES25, ECS25 & ECS50 MOUNTINGS

### TYPE ES

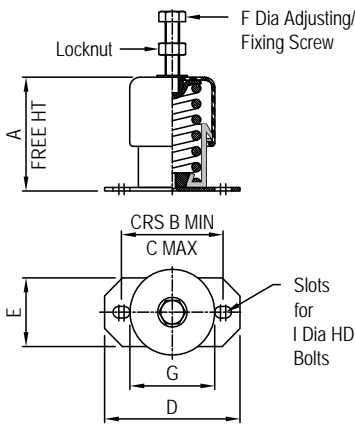

### TYPE ESB

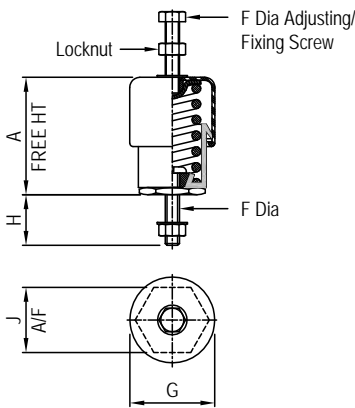

### TYPE ECS

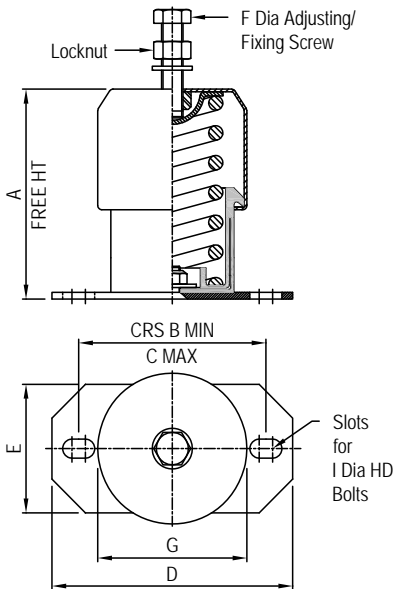

PART No.	COLOUR CODE	RATED LOAD (kg)	DEFLECTION AT RATED LOAD (mm)	DIMENSIONS (mm)										WT (kg) MAX					
				A	B	C	D	E	F	G	H	I	J						
ES20/10	PURPLE	10	20																
ES20/15	YELLOW	15	20																
ES20/20	GREY	20	20	63	54	60	76	38	M8	48	-	M6	-					0.25	
ES20/40	GREEN	40	20																
ES20/70	RED	70	20																
ES15/100	BLUE	100	15																
ESB20/10	PURPLE	10	20																
ESB20/15	YELLOW	15	20																
ESB20/20	GREY	20	20	65	-	-	-	-	M8	48	26	-			36			0.25	
ESB20/40	GREEN	40	20																
ESB20/70	RED	70	20																
ESB15/100	BLUE	100	15																
ES25/30	YELLOW	30	25																
ES25/60	GREEN	60	30																
ES25/100	BLUE	100	25	88	85	90	110	70	M10	78	-	M8	-					1.0	
ES25/160	WHITE	160	25																
ES25/250	RED	250	25																
ECS25/100	WHITE/YELLOW	100	25																
ECS25/200	WHITE/RED	200	25																
ECS25/300	WHITE/PURPLE	300	25																
ECS25/400	WHITE/GREY	400	25																
ECS25/500	WHITE/ORANGE	500	25																
ECS25/600	WHITE/BROWN	600	25	127	130	150	180	95	M16	111	-	M12	-					3.0	
ECS25/700	WHITE/BLACK*	700	25																
ECS25/800	WHITE/GOLD	800	25																
ECS25/1000	WHITE/1000	1000	25																
ECS25/1200	WHITE/1200*	1200	25																
ECS25/1400	WHITE/1400*	1400	25																
ECS50/100	BLACK/YELLOW	100	50																
ECS50/200	BLACK/GREEN	200	50																
ECS50/300	BLACK/BLUE	300	50	155	130	150	180	95	M16	111	-	M12	-					2.8	
ECS50/400	BLACK/WHITE	400	50																
ECS50/500	BLACK/RED	500	50																

\* Internal nested spring.

### ISOLATION EFFICIENCY AT TYPICAL MACHINE SPEEDS

MACHINE SPEEDS (rpm)	EFFICIENCY %		
	15 mm DEFL.	25 mm DEFL.	50 mm DEFL.
300	DO NOT USE	34.0	75.2
500	68.7	83.3	92.3
750	88.1	93.2	96.7
1000	93.7	96.3	98.2
1200	95.7	97.4	98.7
1500	97.3	98.4	99.2
1750	98.0	98.8	99.4
2000	98.5	99.1	99.5

The above figures are theoretical values only based on the vertical natural frequency of the sprung system assuming infinitely stiff structural supports. The effects of high frequency spring coil resonances on low frequency performance are also ignored.

### Seating Pads

Ribbed rubber seating pads can now be fitted as standard, suffix Pt. No. /B e.g. ES25/100/B.

### Stainless Steel.

This option is available across the entire range for external and other hostile environments. When ordering the Pt. No. should be suffixed with /S for Stainless Steel or if fitted with a seating pad /SB e.g. ECS25/500/S or ECS25/500/SB.

### Spring Deflection

Spring stiffness is linear over its working range therefore the actual deflection for a given load can be calculated as follows:-

$$\text{Actual Deflection (mm)} = \frac{\text{Actual Load (kg)} \times \text{Rated Deflection (mm)}}{\text{Rated Load (kg)}}$$

For full installation instructions please refer to our data sheet DS026.

For more detailed information and technical assistance please contact our Technical Department.

In the interests of continual development, the Company reserves the right to make modifications to these details without notice.



## Christie & Grey Limited

Morley Road, Tonbridge, Kent TN9 1RA, England

Telephone : +44 (0) 1732 371100 • Fax: +44 (0) 1732 359666

E-mail : sales@christiegrey.com • web site: www.christiegrey.com

