

# TECHNICAL DATA SHEET

## DS 035

NON CONTROLLED UNLESS STATED OTHERWISE

QCF 56 Issue 3

PAGE

1 of 4

ISSUE

7

DATE

9 April 2015

APPROVED

A.N.M

TITLE. General Installation Procedure for Combined Steel Spring and Rubber Spring Isolators Type TSC Size T3, for non-propulsion applications.

Details of isolators as Leaflet PL001

### General Notes

Isolators comprise of either SG iron or aluminium castings containing 4 No. natural rubber elements and a central steel spring.

An adjustable overload and rebound stop unit is fitted and is visible through the "window" in the lower casting. This is adjusted by turning the M24 stud in the centre of the top of the mounting using a flat screwdriver bit, and is secured by the 36mm A/F locknut.

Adjust the centre bolt in the mount top so that the clearance above the combined overload and rebound washer is as advised on the supplied installation drawing. If not specified, the combined overload and rebound washer should be set to 4 mm clearance above the washer. Tighten the lock nut on the centre bolt to a torque of 200Nm to 220 Nm ( 147.5 lb-ft to 162.3 lb-ft ). A 56mm diameter hole should be provided through the machine bedframe at the isolator position for access to the stud and locknut.

The isolator is secured to the machine bedframe with 4 No. M20 screws into tapped holes in the upper casting, and to the deck seating also by 4 No. M20 screws through clearance holes in the base casting. These screws are not supplied by Christie and Grey but must be of sufficient length to accommodate the frame members and shims as required.

Isolators are not usually suitable for prolonged use in adverse outdoor locations or corrosive atmospheres without further protection - please consult our applications engineers about problem installation areas or special paint finishes.

The isolators should be installed generally in accordance with the following procedure for single bedframe machines.

#### A. Using Steel Shims

- 1) The structure beneath the machine should be constructed to form a rigid and reasonably level seating for each group of isolators.
- 2) The isolators should be examined to ensure they are of the correct variant. If appropriate, the positions for different references should be located in accordance with our recommendations or drawings.
- 3) Either bolt the isolators to the underside of the machine base or position them upon the prepared seating before lowering the machine into position.

# TECHNICAL DATA SHEET

## DS 035

NON CONTROLLED UNLESS STATED OTHERWISE

QCF 56 Issue 3

PAGE

2 of 4

ISSUE

7

DATE

9 April 2015

APPROVED

A.N.M

TITLE.

General Installation Procedure for Combined Steel Spring and Rubber Spring Isolators Type TSC Size T3, for non-propulsion applications.

- 4) Jacks or blocks should be used to support the machine in a level state with a small clearance above or below each isolator. The clearance must be measured and if they vary by more than 1mm then steel or other rigid packing pieces should be fitted before transferring the machine weight onto the isolators. These packing pieces may be fitted above or below the isolators and should be of adequate size with suitable holes for isolator fixing/HD bolts where necessary.
- 5) After the machine weight has been transferred to the isolator, HD or fixing bolts should be fitted, these must not strain the isolator in any direction. The isolators are not designed to accommodate angular misalignment, variations in level, excessive horizontal forces or tensile forces. It is recommended that fixing/HD bolts be tightened to their correct torque values.

If high tensile fixing bolts greater than 8.8 grade are used, please consult our applications department to discuss recommended torque values.

Note: Ensure a thread engagement into upper casting fixing holes of 20 to 30 mm.

### B. Using Resin Chocks

Isolators can be installed with the use of a soleplate to facilitate installation/removal and alignment, particularly if, for example, a flexibly mounted prime mover is driving a solidly mounted gearbox. For installation of marine propulsion engines using TSC T3 see Data Sheet DS013. Installation of isolators with soleplates must be carried out as follows:

- 1) Before positioning isolators it is most important that all levelling screws, HD bolts and underside of soleplate be sufficiently greased to permit removal from resin grout at a later stage.
- 2) Jacks or blocks should be used to support the machine in a level state, with a clearance of 10 to 25 mm typically between underside of bedframe and top of isolator (Figure 1).
- 3) The 4 No. levelling screws should then be wound down evenly, thus raising isolator until level contact with underside of bedframe is made, when fixing bolts can be loosely fitted to ensure isolator position (Figure 2). Isolator HD bolts (if applicable) should now be positioned through soleplate and isolator base castings. These should only locate in foundation/lower seating and must not be tightened down at this stage.

**NB: It is essential that at no time is load applied to the isolator via the levelling screws.**

# TECHNICAL DATA SHEET

## DS 035

NON CONTROLLED UNLESS STATED OTHERWISE

QCF 56 Issue 3

PAGE

3 of 4

ISSUE

7

DATE

9 April 2015

APPROVED

A.N.M

TITLE.

General Installation Procedure for Combined Steel Spring and Rubber Spring Isolators Type TSC Size T3, for non-propulsion applications.

Figure 1.

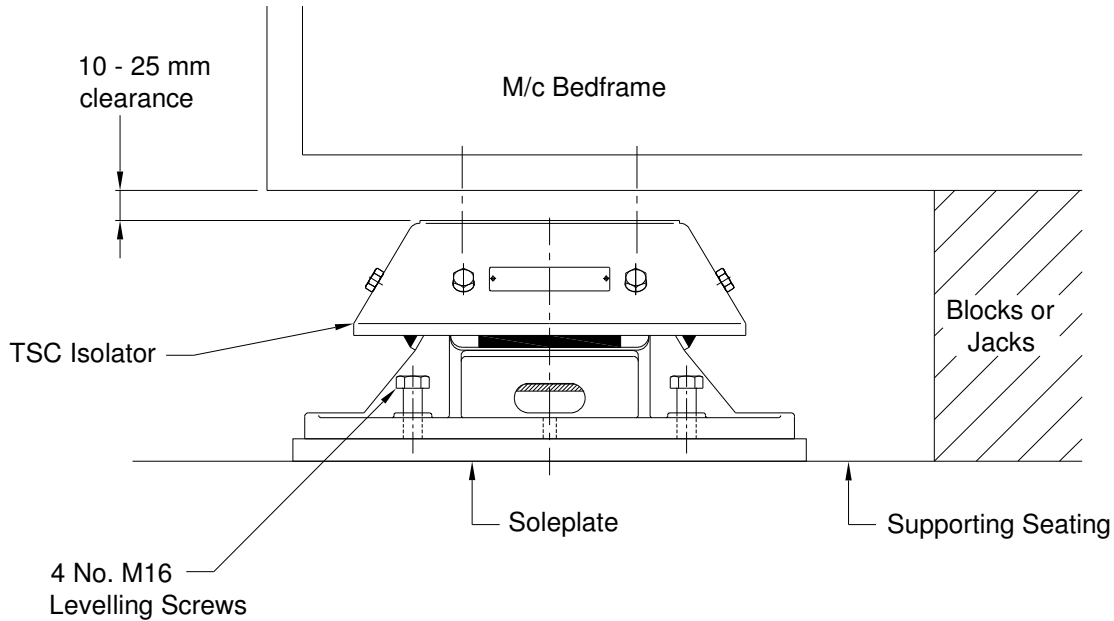
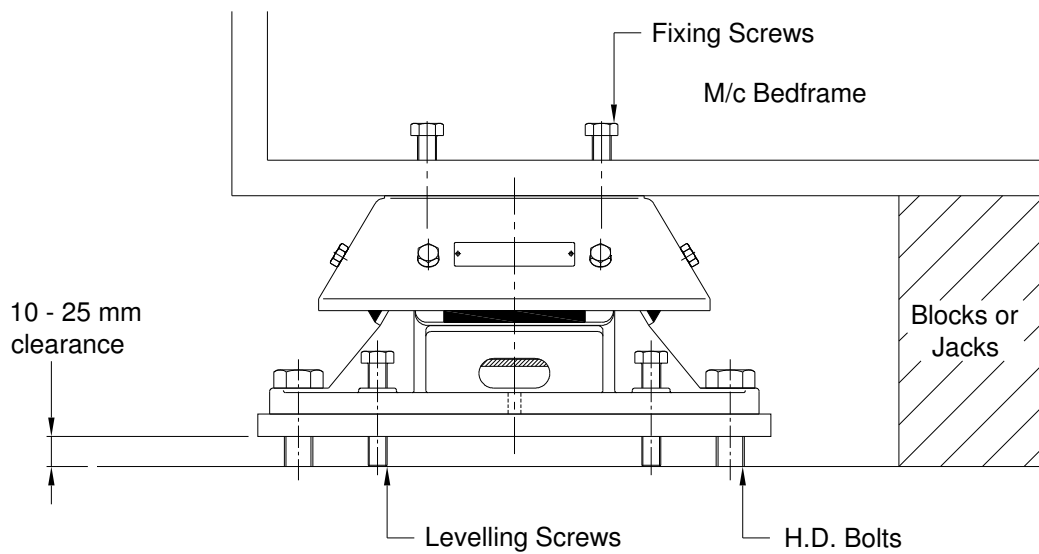

Figure 2.



# TECHNICAL DATA SHEET

## DS 035

NON CONTROLLED UNLESS STATED OTHERWISE

QCF 56 Issue 3

PAGE	4 of 4
ISSUE	7
DATE	9 April 2015
APPROVED	A.N.M

TITLE. General Installation Procedure for Combined Steel Spring and Rubber Spring Isolators Type TSC Size T3, for non-propulsion applications.

- 4) When all the isolators have been leveled, suitable 'dams' should be constructed and resin grout (Chock-Fast Orange or equivalent) poured between underside of the isolator base casting and supporting structure.

After grout has cured, the load may be transferred to the isolators by removing blocks and carefully lowering machine across supported area.

Isolator fixing and HD bolts can then be tightened to their correct torque values (Figure 3).

Figure 3

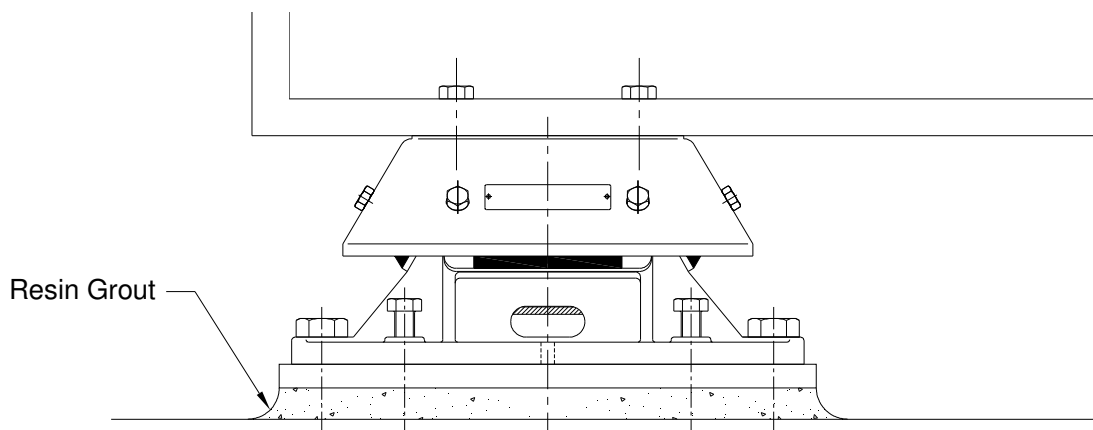

The efficiency of an isolator system can be seriously impaired if the system is connected to rigid pipes, electrical conduits, ducts or shafts. It is essential that such external connections be as flexible as possible, not only to prevent transmission of vibration through the connections and allow the system freedom of movement, but also to avoid possible failure of the connections.

Please contact our Technical Department at the address below if you have any problems relating to installation or selection.



### Christie & Grey Limited

Morley Road, Tonbridge, Kent TN9 1RA, England

Telephone : +44 (0) 1732 371100 • Fax: +44 (0) 1732 359666

E-mail : [sales@christiegrey.com](mailto:sales@christiegrey.com) • web site: [www.christiegrey.com](http://www.christiegrey.com)

