

Marinflex

Type Cushyfloat™



A range of compact rubber unit isolators specially designed for marine and mobile applications.

The Cushyfloat is available in three sizes and three rubber compounds for loads of 12 kg to 780 kg (75 shore rubber available in 17/1657 variant for max load of 1100 kg to special order only).

General type approval has been given by Lloyd's Register of Shipping.

DESIGN FEATURES

- Cushyfloat type mount uses zinc plated steel components.
- Resilient elements are first grade natural rubber to metal bonded units.
- Loading the rubber elements in a combination of shear and compression provides the optimum balance between high load capacity and low stiffness.
- Rubber elements are contained and protected within the top and base metals. The shapes of the top and the rubber elements are designed to increase stiffness and control movement under overload conditions.
- Rebound washers are incorporated to control movement due to ship or vehicle motion.
- High lateral to vertical stiffness ratio of the rubber elements assists in the control of motion and in many instances obviates the need for additional external side and end restraints.
- Low height compact units, ideal for use where space is limited.

TYPICAL APPLICATIONS

- Control Cabinets.
- Hydraulic Pumps and Motors.
- Rotary Compressors.
- Small Marine Diesel Propulsion Engines and Generator Sets.

**LOAD / DEFLECTION GRAPH
CUSHYFLOAT TYPE 17/1600/1**

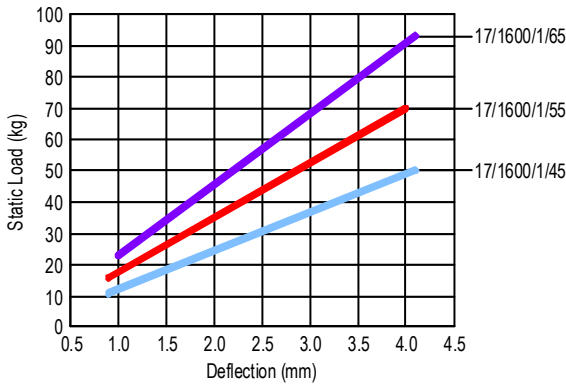

**LOAD / DEFLECTION GRAPH
CUSHYFLOAT TYPE 17/1609/1**

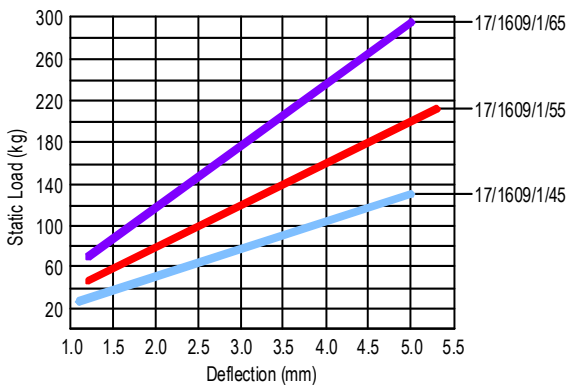

**LOAD / DEFLECTION GRAPH
CUSHYFLOAT TYPE 17/1657/1**

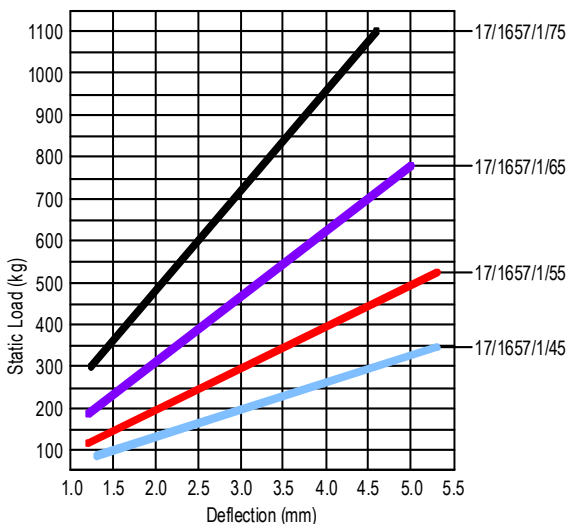

TYPE CUSHYFLOAT RUBBER UNIT ISOLATORS

REFERENCE	DIMENSIONS (mm)										WT (kg) MAX
	A	B	C	D	E	F	G	H	J	K	
17/1600/1	38.5	60	120	100	M12	22	14	11	14	11	0.4
17/1609/1	50	75	183	140	M16	32	13	20	30	13	0.9
17/1657/1	70	112	230	182	M20	50	18	26	34	18	2.25

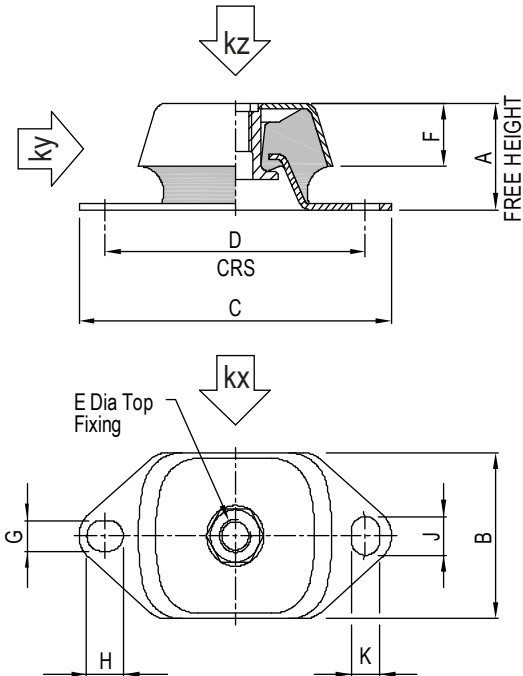

PART No.	LOAD RANGE (kg)	STATIC STIFFNESS (N/mm)			DYNAMIC / STATIC STIFFNESS RATIO
		kx	ky	kz	
17/1600/1/45	12 - 48	90	300	120	1.15
17/1600/1/55	17 - 70	129	430	172	1.25
17/1600/1/65	25 - 91	167	558	223	1.50
17/1609/1/45	30 - 130	200	640	255	1.15
17/1609/1/55	50 - 210	294	980	392	1.25
17/1609/1/65	72 - 290	434	1446	578	1.50
17/1657/1/45	90 - 350	480	1600	640	1.15
17/1657/1/55	125 - 530	730	2430	970	1.25
17/1657/1/65	200 - 780	1150	3830	1530	1.50
17/1657/1/75*	300 - 1100	1770	5890	2355	1.95

Cushyfloat™ is a registered trademark of Metalastik®

* 17/1657/1/75 to special order only.

For full installation instructions please refer to our data sheet DS010.

For more detailed information and technical assistance please contact our Technical Department.

In the interests of continual development, the Company reserves the right to make modifications to these details without notice.



Christie & Grey Limited

Morley Road, Tonbridge, Kent TN9 1RA, England

Telephone : +44 (0) 1732 371100 • Fax: +44 (0) 1732 359666

E-mail : sales@christiegrey.com • web site: www.christiegrey.com

