

Studflex

Type Vibration Isolation Mats & Pads



This market leading design is the most adaptable and effective area isolation product available. It is capable of protecting entire buildings from railway vibration whilst smaller section pads can be used to isolate building Air Conditioning plant.

Studflex isolation mats and pads are manufactured using a range of first grade natural rubber compounds to BS5176 and are available in either a solid or hollow stud design to cover a wide range of applied loads.

A unique feature of the Studflex design is the moulded segments which allow the mat to be cut by hand into individual pads ideal for positioning directly beneath machine feet or base frames.

DESIGN FEATURES

- Moulded in first grade natural rubber to BS5176.
- Manufactured in two designs, solid and hollow, available in various rubber compounds identified by a colour spot.
- Static deflections of 4 mm with loads of up to 6540 kg per mat (400 x 400) single layer. Deflections of 8 mm for double layer pads.
- Solid variants also available as moulded double layer pads with integral steel interleaves.
- Studflex isolation mats can be assembled in layers using steel interleaves for increased deflection and lower natural frequencies.

TYPICAL APPLICATIONS

- Acoustic Floating Floors for Cinemas, Recording Studios and Plant Rooms. See Leaflet PL011 SRS Floating Floors.
- Steelwork and partition wall isolation.
- Isolation of low rise buildings from railway and other vibration and noise.
- Machinery Foundation Blocks.
- Secondary Isolation of Air Handling Units.
- Isolation of Sensitive Equipment.
- With Inertia Bases type IPF for Pumps etc.

STUDFLEX MATS

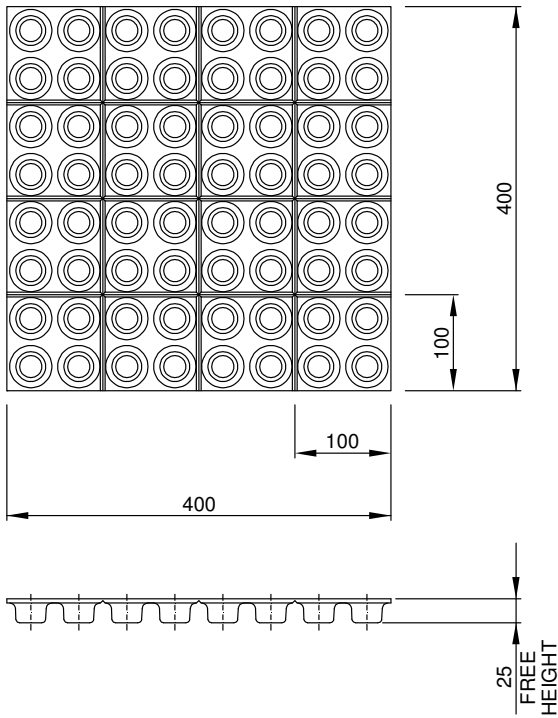

WHOLE MATS - 400 mm x 400 mm x 25 mm					
PART No.	TYPE	COLOUR CODE	MAXIMUM LOAD PER MAT (kg)	LOAD PER 4 STUD SECTION (kg)	MAT WEIGHT (kg) MAX
05.101.35	Hollow Stud	Yellow	1300	81	1.55
05.101.45	Hollow Stud	Blue	2120	132	1.64
05.102.45	Solid Stud	Blue	3040	190	1.9
05.102.55	Solid Stud	Red	4400	275	1.97
05.102.65	Solid Stud	Purple	6540	408	2.2



LOAD / DEFLECTION CHARACTERISTICS

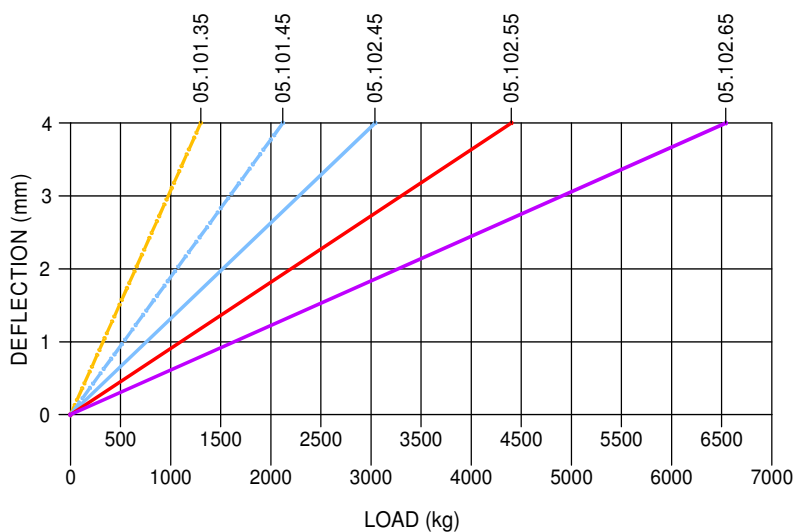

NATURAL FREQUENCY v STATIC LOAD

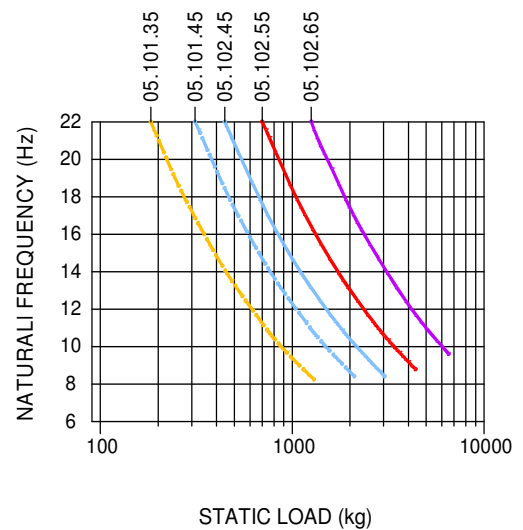

The maximum loads stated above are calculated at 4 mm vertical deflection and are subject to a production tolerance of + / - 20%. Studflex mats should be protected from severe contamination by mineral oils.

For full installation instructions please refer to our data sheet DS030.

For more detailed information and technical assistance please contact our Technical Department.

In the interests of continual development, the Company reserves the right to make modifications to these details without notice.



Christie & Grey Limited

Morley Road, Tonbridge, Kent TN9 1RA, England

Telephone : +44 (0) 1732 371100 • Fax: +44 (0) 1732 359666

E-mail : sales@christiegrey.com • web site: www.christiegrey.com



DOUBLE LAYER STUDFLEX PADS

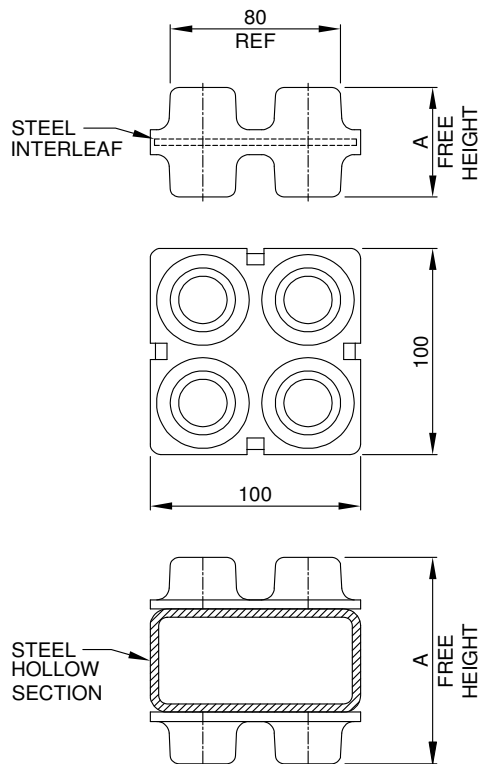

STUDFLEX PADS (DOUBLE LAYER) - 100 mm x 100 mm x "A" mm					
PART No.	TYPE	COLOUR CODE	LOAD PER 4 STUD SECTION (kg)	FREE HEIGHT "A" (mm)	PAD WEIGHT (kg) MAX
05.104.35	Hollow 35	Yellow	81	53	0.43
05.104.45	Hollow 45	Blue	132	53	0.44
05.103.45	Solid 45	Blue	190	53	0.44
47248/S45				100	1.1
05.103.55	Solid 55	Red	275	53	0.44
47248/S55				100	1.1
46930/S55				150	1.4
05.103.65	Solid 65	Purple	408	53	0.45
47248/S65				100	1.1
46930/S65				150	1.5



LOAD / DEFLECTION CHARACTERISTICS

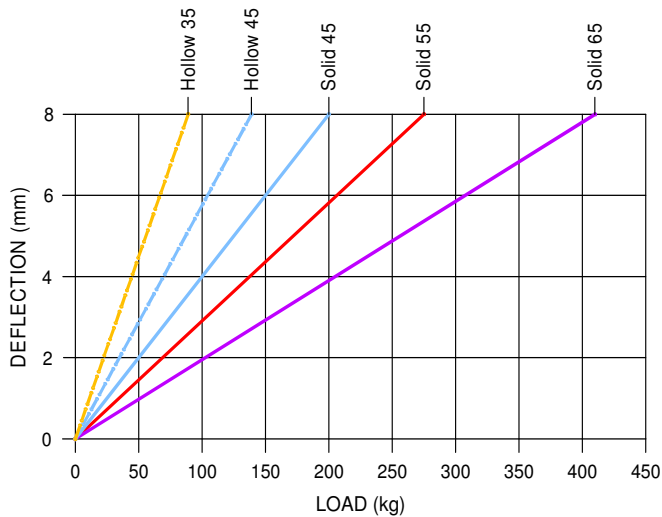

NATURAL FREQUENCY v STATIC LOAD

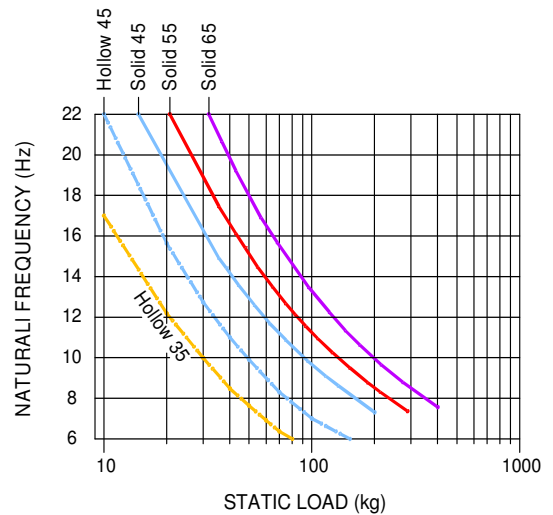

The maximum loads stated above are calculated at 8 mm vertical deflection and are subject to a production tolerance of + / - 20%. Studflex pads should be protected from severe contamination by mineral oils.

For full installation instructions please refer to our data sheet DS030.

For more detailed information and technical assistance please contact our Technical Department.

In the interests of continual development, the Company reserves the right to make modifications to these details without notice.



Christie & Grey Limited

Morley Road, Tonbridge, Kent TN9 1RA, England

Telephone : +44 (0) 1732 371100 • Fax: +44 (0) 1732 359666

E-mail : sales@christiegrey.com • web site: www.christiegrey.com



SPECIAL VARIANT STUDFLEX PADS

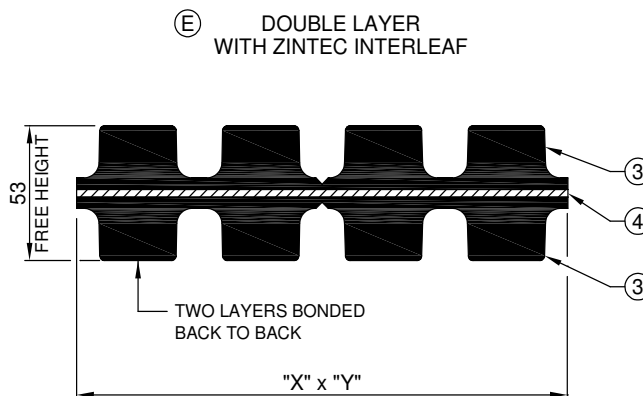
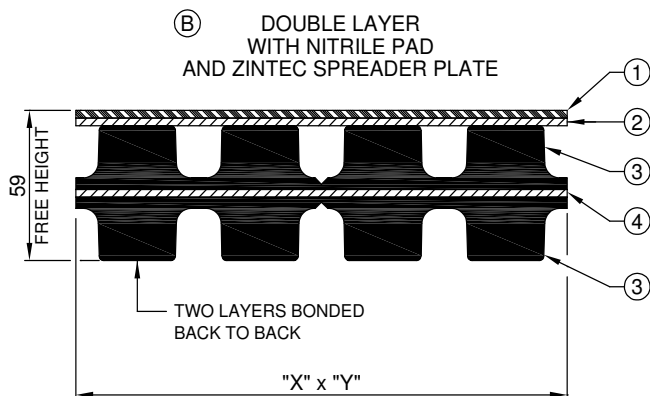
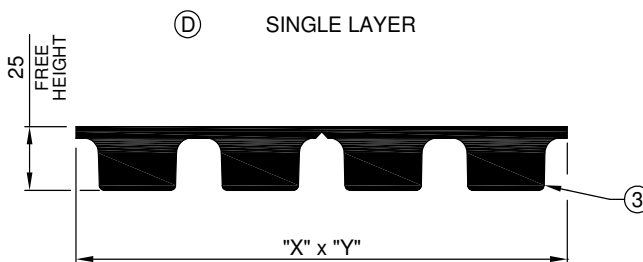
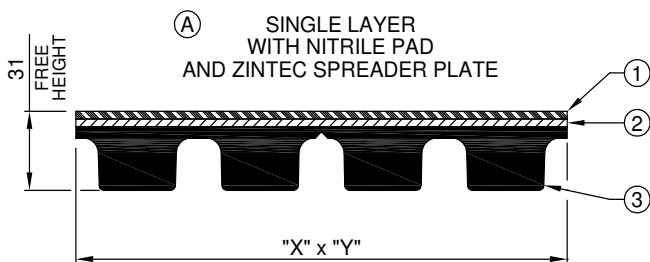

Parts List.

1. 3 mm Nitrile Pad bonded to Item 2.
2. 3 mm Zintec Steel Spreader plate bonded to Item 3.
3. Studflex Pad (s) type, compound and size to be specified. See Part No. example below.
4. 3 mm Zintec Steel Interleaf bonded to Studflex Pad(s) size X x Y



Part No. Example : H552010A

(55° Shore) COMPOUND	(Single Layer with Nitrile Pad & Spreader Plate) STYLE
H 55	20 10 A
(Hollow Stud) TYPE	(200mm x 100mm) SIZE

Type Options : Hollow or Solid Stud

Compound Options : **Hollow** 35 or 45
Solid 45, 55 or 65

Size Options : Special Studflex pads can be supplied in modular sizes where "X" & "Y" are any multiple of 100 mm up to 400 mm square.
10 = 100mm, 20 = 200mm, 30 = 300mm and 40 = 400mm.

Style Options : As shown above, A, B, D or E.

Load and deflection characteristics should be calculated as a proportion of a whole Studflex mat (consult our Technical Department for assistance in selection).

Studflex pads should be protected from severe contamination by mineral oils.

For full installation instructions please refer to our data sheet DS030.

For more detailed information and technical assistance please contact our Technical Department.

In the interests of continual development, the Company reserves the right to make modifications to these details without notice.



Christie & Grey Limited

Morley Road, Tonbridge, Kent TN9 1RA, England

Telephone : +44 (0) 1732 371100 • Fax: +44 (0) 1732 359666

E-mail : sales@christiegrey.com • web site: www.christiegrey.com

