

Stud Rail System for Floating Floors

Type SRS

The principle of supporting two separate masses to significantly improve the standard acoustic mass law performance is well understood. The term "Floating Floor" is a relatively new expression that has gained favour in more recent years but the method of supporting a floor structure on resilient bearings off a structural slab has been applied and developed by Christie & Grey over much of its 90 year history. Examples of this work still in existence date back to the early 1960's.

The development of structural materials has enabled architects and engineers to make more and more use of lightweight structures in modern building design. This has highlighted the need to consider carefully the noise, shock and vibration transmission loss characteristics of these structures. In particular, for high rise buildings, the proximity of "noisy or high" and "quiet or critical" areas significantly increases the potential for use of acoustic and vibration isolation materials, including floating floors. For example, it might be necessary to isolate a plant room from office accommodation below, reduce external noise such as low flying aircraft penetrating the roof of a building or reducing transmission of footfall impact noise from one apartment to another below.



SRS floating floor systems have been successfully used in applications such as Plant rooms, Offices, Prestigious Apartment Blocks, TV, Radio and Recording Studios, Cinemas, Concert Halls and Audiometry rooms.

DESIGN FEATURES

- Laminated steel and natural rubber elastomer bearings are located beneath rigid steel channels positioned to suit the load distribution arrangement.
- Natural rubber bearings are true elastomers and are applied within their linear stiffness range to achieve the required design performance, low creep and resultant design life.
- Standard design can provide natural frequencies down to 6 Hz.
- Profile permanent steel shuttering keyed to concrete for greater rigidity of floating floor slab.
- All steel is galvanized and elastomer bearings are unaffected by water, vermin or other pests.
- Floor thickness from 100 - 300 mm with imposed loads of up to 20 kN/m².
- Sound transmission loss is dependent upon concrete thickness and air space. Typically a type SRS floating floor can be designed to provide a loss of at least 20 - 25 dB in excess of that provided by a single concrete slab construction.
- Under the design condition, the life of a SRS floating floor system will be at least the life of the building.

TYPICAL CONSTRUCTION

Floating floors can be provided externally on the roof as well as within the building. The form of construction is similar for both instances although additional treatment is required to fully weatherproof the external floating floor.

MATERIALS

The following materials are supplied to permit the construction of a floating floor.

- Laminated steel and natural rubber elastomer pads type "Studflex".
- Galvanised steel channel rails.
- Galvanised steel profile permanent shuttering.
- Peripheral resilient lining material.
- Permanent resilient peripheral sealant to suit application.
- Where required, thermal/acoustic mineral wool void filler, fire barriers, damp-proof membrane, edge closure materials and floor drains can be supplied.

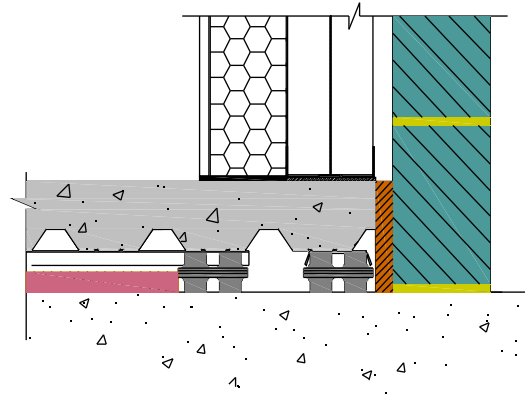

Section through a floating floor showing the typical construction at the perimeter with pads added to support an internal wall.

TYPICAL "ROOM WITHIN A ROOM" CONSTRUCTION

Alternative materials and forms of construction are available for use in specific applications.

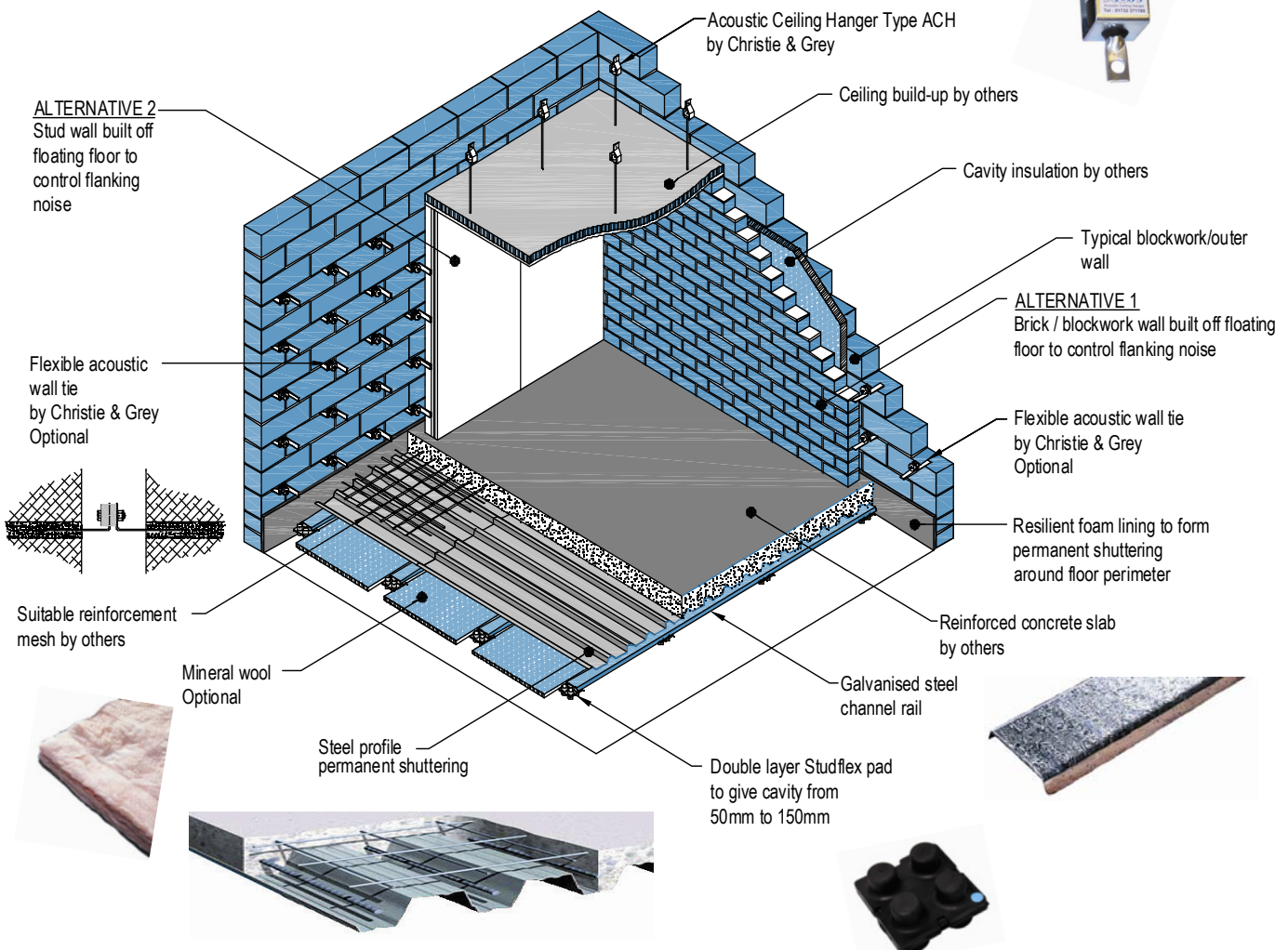

For full installation instructions please refer to our data sheet DS036.

In the interests of continual development, the Company reserves the right to make modifications to these details without notice.



Christie & Grey Limited

Morley Road, Tonbridge, Kent TN9 1RA, England

Telephone : +44 (0) 1732 371100 • Fax: +44 (0) 1732 359666

E-mail : sales@christiegrey.com • web site: www.christiegrey.com



ACOUSTIC BUILDING ISOLATION TREATMENT

Christie & Grey can provide products to cater for all aspects of Building Isolation. Care is taken in providing penetrations through the floating floor for such things as drains, pipes, electrical conduits so as to avoid building "short circuits".

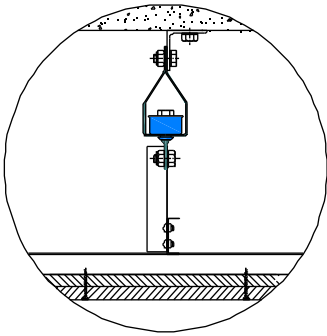

Acoustic Ceiling Hangers

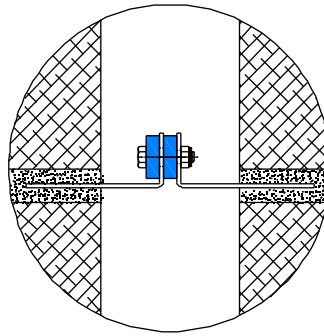

Flexible Acoustic Wall Ties

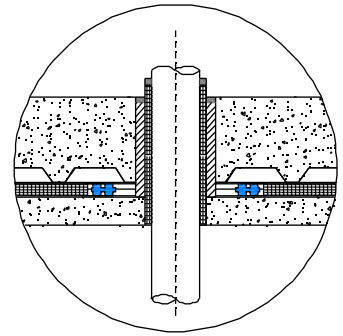

Penetration Detail

STUD RAIL SYSTEM PERFORMANCE

The acoustic performance (airborne noise only) of a concrete floor slab can be estimated by the "Mass Law". If the sound reduction index (SRI) of a given thickness of floor slab is insufficient for a given application, then the logical approach would be to increase the slab thickness. However, the Mass Law relationship shows that by doubling the thickness, the SRI increases by only about 5 dB and the subsequent problem of providing additional structure to support very heavy floors may be impractical, particularly in high rise buildings.

By decoupling two floor masses with an air gap between, the SRI of the total structure under perfect conditions will be approximately the sum of the SRI's of the individual masses. In practice, this is never quite achieved because of the flanking transmission and low order coupling via the airspace between the two masses. In the case of the SRS system, the space between the channel rails is filled with mineral wool which has the advantage of reducing the build up of reverberant noise and acoustic resonances within the air space and also provides an additional thermal barrier.

For critical applications such as TV, Radio and Recording Studios, Audiometry rooms, Anechoic and Reverberant Acoustic Test Chambers, internal walls can be supported off the floating floor to reduce the effect of flanking noise transmission.

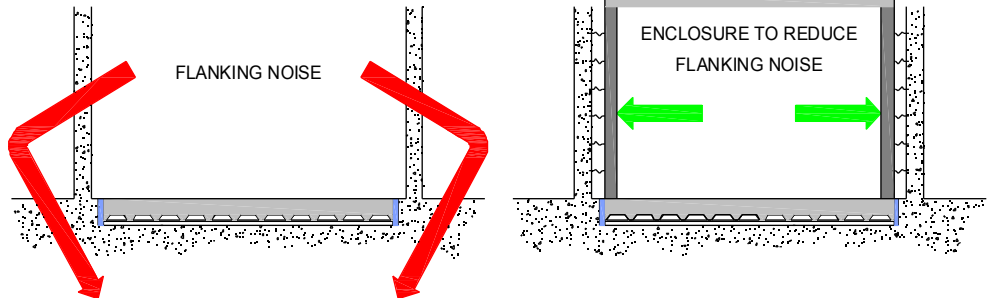

To control the transmission of structure borne noise, the SRS system in standard form has significant advantages over other systems in that it is possible to design a floating floor with natural frequencies down to 6 Hz (for exceptional circumstances, lower frequencies can be achieved).

In many circumstances, this may permit plant to be located directly on the floor or at least mounted off the floor with a simple spring or rubber vibration isolation system. In the situation where a massive item of equipment needs to be located on the floating floor, which may cause a significant asymmetric loading condition, it may be necessary to provide a machinery plinth which locally penetrates the floating floor structure upon which the individual item of plant may be mounted and isolated in the most appropriate manner. Where internal walls are supported off the floating floor, flexible acoustic wall ties can be provided to brace between internal and external walls to maintain both structural and acoustic integrity.

Irrespective of the complexity of the application, a comprehensive design and site installation service using our own experienced staff is provided to ensure specified noise criteria are met and maintained.

The SRS floating floor system has been subjected to tests by independent consultants in accordance with International Standards and the static and dynamic characteristics of the natural rubber elastomer bearings have also been independently tested.

For more detailed information and technical assistance please contact our Technical Department.

In the interests of continual development, the Company reserves the right to make modifications to these details without notice.



Christie & Grey Limited

Morley Road, Tonbridge, Kent TN9 1RA, England

Telephone : +44 (0) 1732 371100 • Fax: +44 (0) 1732 359666

E-mail : sales@christiegrey.com • web site: www.christiegrey.com



REFERENCES

Cinemas / Entertainment

- Vue
- Odeon & UCI
- The O2
- Cineworld
- Tiger Tiger
- Showcase
- British Music Experience
- Hoyts
- UGC/Virgin
- Cinemark
- Jumpin Jacks
- Ster-Century
- Luminar
- Sony BMG

Studios

- BBC
- Classic FM
- Channel 5
- Scream Studios
- Birmingham Hippodrome
- University of Glamorgan
- The Hit Factory New York / Miami - Grand Central
- EMI
- Corinthian TV
- Pearson TV
- Film City Glasgow
- Windmill Lane Dublin
- ARD Television

Audiology Rooms

- Cheltenham Hospital
- Hodge Hill School, Birmingham
- Wycombe Hospital

Plantrooms / Industrial & Commercial

- London Metropol Hotel
- Holiday Inn Hotel
- University of Hertfordshire
- Thwaites Brewery
- University of Teesside
- Ford Motor Company
- Honda UK
- Travelodge
- Oxford Brookes University

TYPICAL APPLICATIONS

- TV, Radio and Recording Studios.
- Cinemas.
- Bowling Alleys.
- Nightclubs.
- Prestigious Apartment Blocks.
- Anechoic Chambers.
- Offices.
- Concert Halls.
- Dance Studios.
- Plantrooms.
- Audiometry rooms.
- Test Cells.

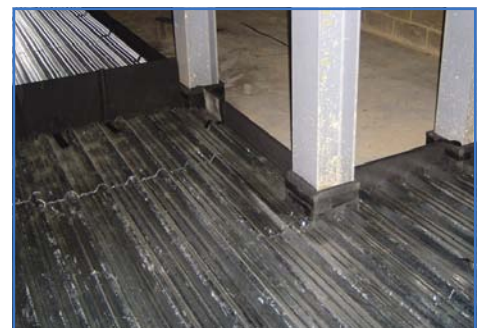
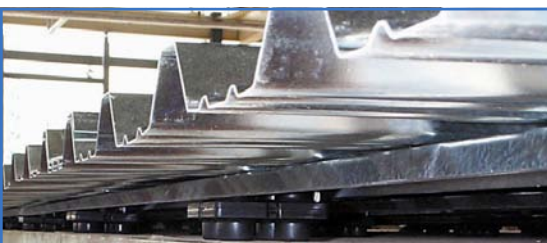
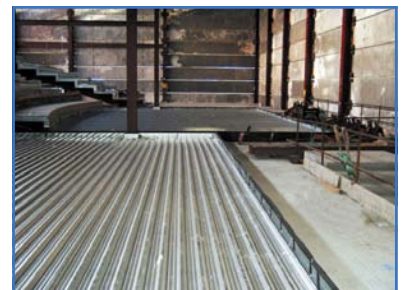

For more detailed information and technical assistance please contact our Technical Department.

In the interests of continual development, the Company reserves the right to make modifications to these details without notice.



Christie & Grey Limited

Morley Road, Tonbridge, Kent TN9 1RA, England

Telephone : +44 (0) 1732 371100 • Fax: +44 (0) 1732 359666

E-mail : sales@christiegrey.com • web site: www.christiegrey.com

