

Open Restrained Spring Mountings

Types ORS25 & ORS50 - 2 & 4 Spring Variants



The ORS mounting has been designed specifically for applications where transmission of low frequency machinery vibration to a building structure must be reduced to avoid physical damage or annoyance to the occupants.

It is a low frequency mounting specifically designed to limit vertical movement on equipment such as cooling towers and chillers. This could otherwise be excessive due to the low stiffness springs required to provide isolation of low frequency vibration.

Applications located at roof level can be successfully mounted on ORS units as any movement caused by high wind loads will be limited. Equipment which contains large volumes of liquid will benefit from installation on ORS mountings because during “draining down” upward movement is restricted thus avoiding damage to pipework and electrical connections.

DESIGN FEATURES

- High strength all steel construction epoxy powder coated finish with B.Z.P fixings as standard.
- Optional Stainless steel fixings available.
- Colour coded helical steel springs to BS1726 Class B with nominal deflections of 25 mm and 50 mm and up to 50% overload capacity also O/D equal to at least 80% of working height.
- Vertical and lateral restraints have rubber inserts to avoid metallic contact and adequate radial clearance ensures isolation efficiency is not impaired.
- Springs located and seated on rubber washers to reduce high frequency transmission.
- Working height and vertical limiting stops are fully adjustable.
- 6 mm thick ribbed rubber seating pad supplied as standard.

TYPICAL APPLICATIONS

- Cooling Towers.
- Chillers.
- Large Fans.
- Air Handling Units.

TYPE ORS25 & ORS50

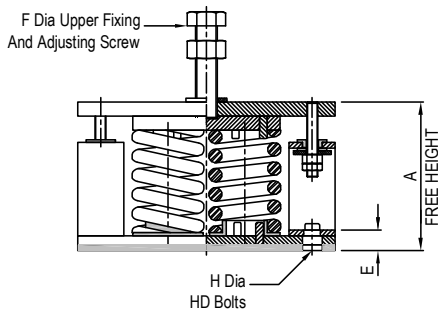

TYPE ORS25/2 & ORS50/2 2 SPRING VARIANT

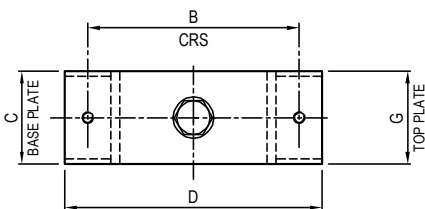

TYPE ORS25/4 & ORS50/4 4 SPRING VARIANT

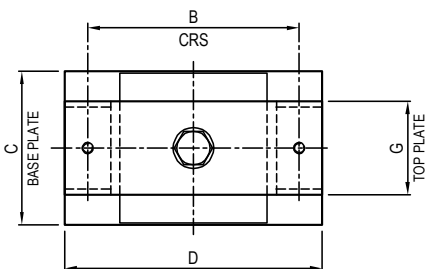

Stainless Steel Fixings.

This option is available across the entire range.

When ordering the Pt. No. should be suffixed with /S for Stainless Steel Fixings e.g. ORS25/4/800/S.

Spring Deflection

Spring stiffness is linear over its working range therefore the actual deflection for a given load can be calculated as follows:-

$$\text{Actual Deflection (mm)} = \frac{\text{Actual Load (kg)} \times \text{Rated Deflection (mm)}}{\text{Rated Load (kg)}}$$

For full installation instructions please refer to our data sheet DS025.

For more detailed information and technical assistance please contact our Technical Department.

In the interests of continual development, the Company reserves the right to make modifications to these details without notice.

TYPE ORS MOUNTINGS - SIZE ORS25/2 SPRINGS & ORS25/4 SPRINGS

PART No.	COLOUR CODE	RATED LOAD (kg)	DEFLECTION AT RATED LOAD (mm)	DIMENSIONS (mm)								WT (kg) MAX	
				A	B	C	D	E	F	G	H		
ORS25/2/200	YELLOW	200	25										
ORS25/2/400	RED	400	25										
ORS25/2/600	PURPLE	600	25										
ORS25/2/800	GREY	800	25	160	230	100	280	22	M24 x 100	100	M16	12.4	
ORS25/2/1000	ORANGE	1000	25										
ORS25/2/1200	BROWN	1200	25										
ORS25/2/1600	BLACK	1600	25										
ORS25/2/2000	BLUE	2000	25										
ORS25/4/400	YELLOW	400	25										
ORS25/4/800	RED	800	25										
ORS25/4/1200	PURPLE	1200	25										
ORS25/4/1600	GREY	1600	25	160	230	165	280	22	M24 x 100	100	M16	16.4	
ORS25/4/2000	ORANGE	2000	25										
ORS25/4/2400	BROWN	2400	25										
ORS25/4/3200	BLACK	3200	25										
ORS25/4/4000	BLUE	4000	25										

TYPE ORS MOUNTINGS - SIZE ORS50/2 SPRINGS & ORS50/4 SPRINGS

PART No.	COLOUR CODE	RATED LOAD (kg)	DEFLECTION AT RATED LOAD (mm)	DIMENSIONS (mm)								WT (kg) MAX	
				A	B	C	D	E	F	G	H		
ORS50/2/200	YELLOW	200	50										
ORS50/2/400	GREEN	400	50										
ORS50/2/600	BLUE	600	50	187	230	100	280	22	M24 x 100	100	M16	13.3	
ORS50/2/800	WHITE	800	50										
ORS50/2/1000	RED/BLACK	1000	50										
ORS50/4/400	YELLOW	400	50										
ORS50/4/800	GREEN	800	50										
ORS50/4/1200	BLUE	1200	50	187	230	165	280	22	M24 x 100	100	M16	16.3	
ORS50/4/1600	WHITE	1600	50										
ORS50/4/2000	RED/BLACK	2000	50										

ISOLATION EFFICIENCY AT TYPICAL MACHINE SPEEDS

MACHINE SPEEDS (rpm)	EFFICIENCY %	
	25 mm DEFL.	50 mm DEFL.
300	34.0	75.2
500	83.3	92.3
750	93.2	96.7
1000	96.3	98.2
1200	97.4	98.7
1500	98.4	99.2

The above figures are theoretical values only based on the vertical natural frequency of the sprung system assuming infinitely stiff structural supports. The effects of high frequency spring coil resonances on low frequency performance are also ignored.



Christie & Grey Limited

Morley Road, Tonbridge, Kent TN9 1RA, England

Telephone : +44 (0) 1732 371100 • Fax: +44 (0) 1732 359666

E-mail : sales@christiegrey.com • web site: www.christiegrey.com

