

TSC Combined Steel Spring and Rubber Spring Unit Isolators

Sizes T1, T2, T3 & T10



A major advance in design has successfully combined the best characteristics of steel springs and rubber springs to produce an efficient, compact and economical range of unit isolators suitable for many types of applications. Many variants of these isolators, designed and manufactured by us have now been in service for more than twenty years.

TSC unit isolators are highly effective in reducing the transmission of vibration, structure-borne noise and shock from a wide range of rotating and reciprocating machinery and in protecting sensitive apparatus from external disturbances. They are particularly suitable for marine and mobile applications as internal snubbers are incorporated to control movement of the isolated machine.

Type approval by Det Norske Veritas and general type approval has been given by Lloyd's Register of Shipping.

DESIGN FEATURES

- Helical steel spring to BS1726 Class B.
- Inclined rubber springs are first grade natural rubber to metal bonded elements.
- SG iron castings to BS EN 1563 EN-GJS-400/15. Alternative lightweight aluminium castings to BS EN 1706 (Size T3 only).
- Steel spring in most variants is isolated from the top casting by resilient seating pad reducing transmission of high frequency vibration and effectively damping spring coil surge resonance.
- Springs are pre-compressed on assembly, resulting in high equivalent static deflection and load capacity with minimum change between loaded and unloaded height.
- Rubber spring elements are effectively protected by the top casting and its extended skirt.
- Both types of spring support a proportion of the total load and thus the overall rate of creep is much reduced compared to an equivalent all-rubber unit isolator.
- A selection of steel and rubber springs, each having different vertical and lateral stiffness closely controlled in manufacture is available to facilitate the choice of the most appropriate isolator characteristics for a particular application.
- Combined rebound and overload buffer is adjustable to permit optimum setting to be achieved throughout service life (Size T3 only).
- Optional soleplate is available to facilitate installation on resin chocks.
- Optional proof plates are available to enable removal of mountings for refurbishment (marine propulsion engines only).

TYPE TSC ISOLATORS SIZES T1 & T2

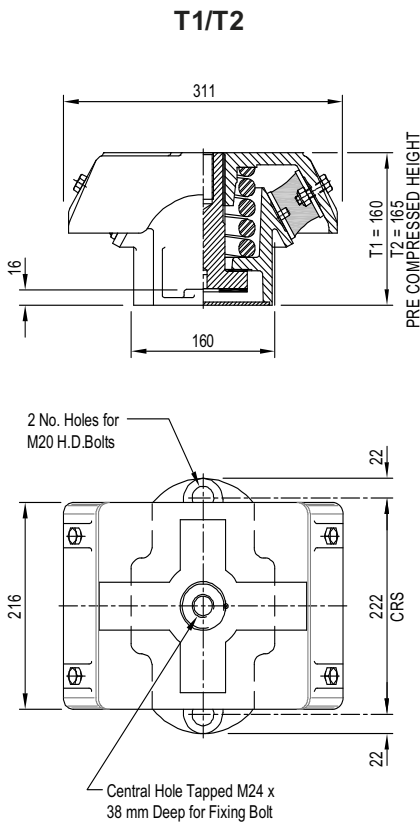

REFERENCE	VERTICAL LOAD RANGE (kg)	DYNAMIC STIFFNESS (kN/m)			WEIGHT (kg) MAX
		VERTICAL	HORIZONTAL		
			kz	kx	
T1 15/45	900 - 1300	1221	2912	583	29.3
T1 20/45	1200 - 1600	1310	3036	717	
T1 25/45	1500 - 1950	1373	3140	798	
T1 30/45	1900 - 2250	1519	3295	966	
T1 20/60	1400 - 2100	2560	5861	1050	
T1 25/60	1750 - 2350	2667	5934	1137	
T1 30/60	2000 - 2800	2772	6097	1300	
T1 40/60	2800 - 4000	3689	7589	2777	
T1 20/70	1600 - 2350	4250	10791	1714	
T1 25/70	1800 - 2800	4341	10873	1805	
T1 30/70	2200 - 3150	4446	11068	1958	
T1 40/70	2900 - 4100	5358	12570	3446	
T2 15/45	1180 - 1360	762	1141	546	28.8
T2 20/45	1290 - 1600	858	1265	678	
T2 20/55	1500 - 1800	1183	1817	787	
T2 20/60	1700 - 2170	1488	2591	983	
T2 25/60	2080 - 2500	1586	2688	1070	
T2 30/60	2370 - 2750	1694	2840	1232	
T2 30/70	2600 - 3150	2627	4697	1716	
T2 30/75	2800 - 3560	3955	7193	2310	
T2 40/60	2750 - 3900	2610	4336	2699	
T2 40/70	3200 - 4200	3538	6161	3186	

- All values of stiffness are nominal subject to $\pm 15\%$ variation on final assembly. The isolator rubber elements are pre-loaded 6 mm upon assembly.
- Stiffness is linear over working load range.
- Dynamic stiffness may vary with frequency. Values stated are reliable for calculation of low frequency characteristics below 100 Hz.

Typical Installation

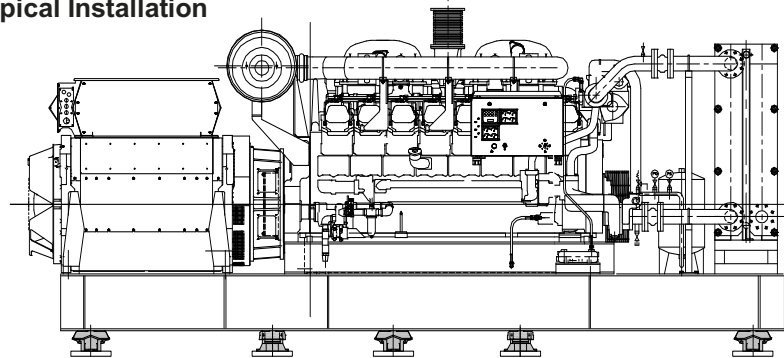
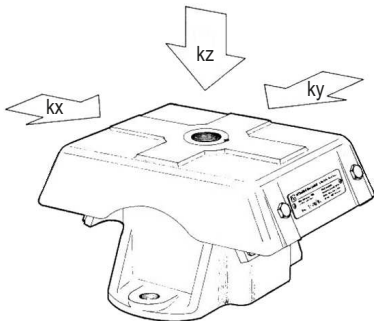

Diesel driven alternator set on T2 isolators

Application Notes:

- Optimum system stiffness characteristics can be achieved by careful orientation of individual isolators.
- All connections to and from isolated machine must include flexible lengths, not only to prevent transmission of vibration through the connections and allow the system freedom of movement, but also to avoid possible failure of the connections.
- Analysis of the isolated system is normally undertaken by Christie & Grey to predict the response to ship motion, machine forces and shocks to enable the correct selection of flexible connections.

For full installation instructions please refer to our data sheets DS022 and DS040.

For more detailed information and technical assistance please contact our Technical Department.

In the interests of continual development, the Company reserves the right to make modifications to these details without notice.



Christie & Grey Limited

Morley Road, Tonbridge, Kent TN9 1RA, England

Telephone : +44 (0) 1732 371100 • Fax: +44 (0) 1732 359666

E-mail : sales@christiegrey.com • web site: www.christiegrey.com



TYPE TSC ISOLATOR SIZE T3

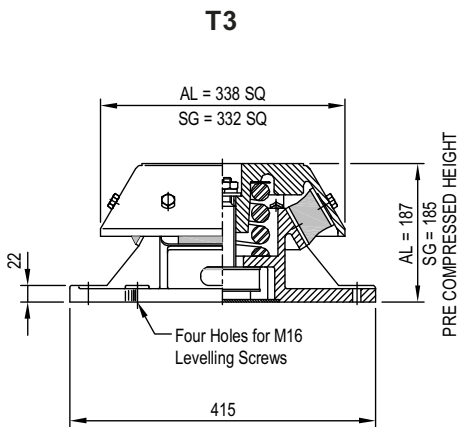

REFERENCE	VERTICAL LOAD RANGE (kg)	DYNAMIC STIFFNESS (kN/m)		WEIGHT (kg) MAX
		VERTICAL	HORIZONTAL	
T3 35/20	1100 - 1700	1050	1269	52.3
T3 45/20	1300 - 2000	1375	1501	
T3 35/40	1500 - 3000	2163	3016	
T3 55/20	1600 - 2700	2040	2166	
T3 45/40	1700 - 3400	2493	3224	
T3 60/20	1800 - 3200	2665	3148	
T3 55/40	2100 - 3950	3135	3905	
T3 55/30	2150 - 3700	2243	2422	
T3 60/40	2350 - 4600	3772	4879	
T3 70/40	2700 - 5300	5609	7182	
T3 60/50L	3500 - 5600	4037	4463	
T3 60/60L	4200 - 6500	4687	5419	
T3 70/60L	4400 - 7250	6165	7294	

- All values of stiffness are nominal subject to $\pm 15\%$ variation on final assembly. The isolator rubber elements are pre-loaded 6 mm upon assembly (with aluminium bases by 4 mm).
- Stiffness is linear over working load range.
- Dynamic stiffness may vary with frequency. Values stated are reliable for calculation of low frequency characteristics below 100 Hz.

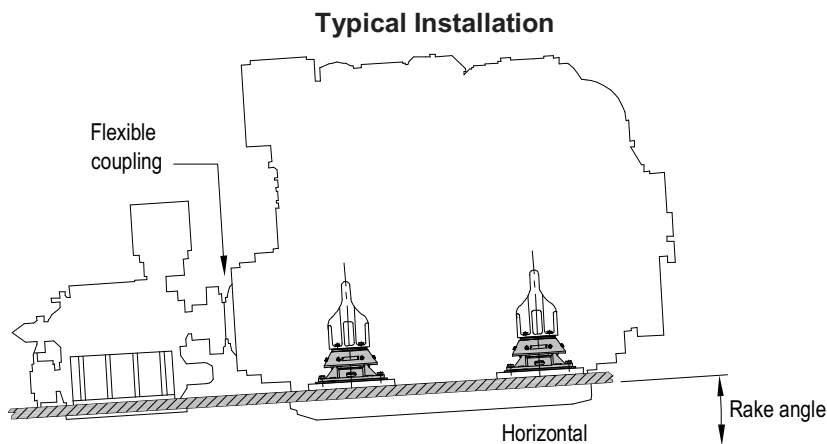
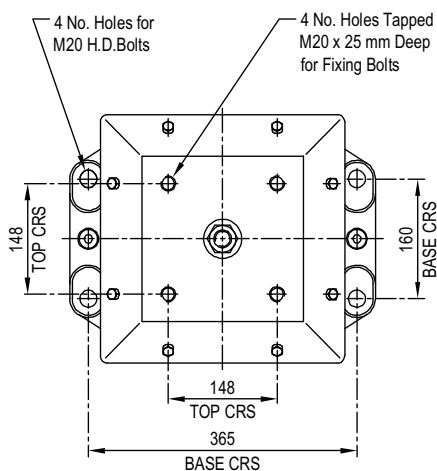

Marine diesel propulsion engine on T3 isolators

Application Notes:

- All connections to and from isolated machine must include flexible lengths, not only to prevent transmission of vibration through the connections and allow the system freedom of movement, but also to avoid possible failure of the connections.
- Provision is made for levelling screws in the base of each isolator to facilitate installation and alignment, particularly if, for example, a flexibly mounted prime mover is driving a solidly mounted gearbox.
- Analysis of the isolated system is normally undertaken by Christie & Grey to predict the response to ship motion, machine forces and shocks to enable the correct selection of flexible connections.

For full installation instructions please refer to our data sheets DS013, DS035 and DS040.

For more detailed information and technical assistance please contact our Technical Department.

In the interests of continual development, the Company reserves the right to make modifications to these details without notice.



Christie & Grey Limited

Morley Road, Tonbridge, Kent TN9 1RA, England

Telephone : +44 (0) 1732 371100 • Fax: +44 (0) 1732 359666

E-mail : sales@christiegrey.com • web site: www.christiegrey.com



TYPE TSC ISOLATOR SIZE T10

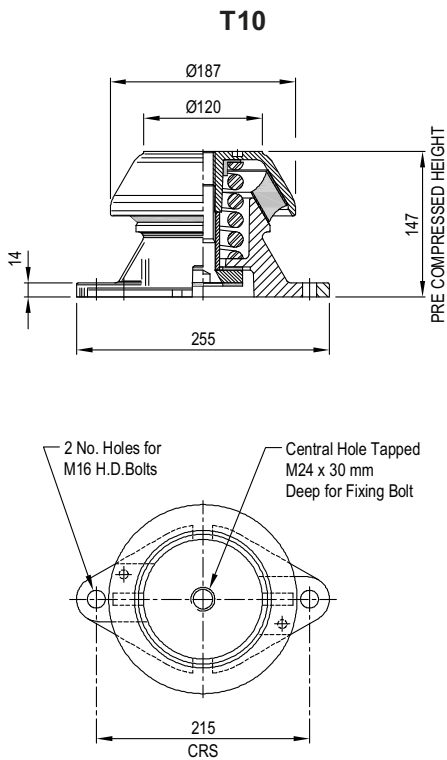

REFERENCE	VERTICAL LOAD RANGE (kg)	DYNAMIC STIFFNESS (kN/m)		WEIGHT (kg) MAX
		VERTICAL	HORIZONTAL	
T10 45/100	400 - 700	752	813	9.0
T10 45/200	450 - 750	779	833	
T10 45/300	510 - 860	848	898	
T10 45/400	560 - 910	850	910	
T10 45/500	620 - 950	854	905	
T10 45/600	720 - 1050	973	1022	
T10 45/800	830 - 1200	987	1016	
T10 45/1000	1150 - 1550	1248	1273	
T10 65/200	960 - 1690	2421	2682	9.0
T10 65/300	1020 - 1790	2439	2676	
T10 65/400	1060 - 1810	2442	2693	
T10 65/500	1130 - 1910	2476	2727	
T10 65/600	1200 - 2000	2535	2738	
T10 65/800	1320 - 2150	2576	2781	
T10 65/1000	1600 - 2500	2712	2902	
T10 65/1500	2100 - 3000	2618	2743	

- All values of stiffness are nominal subject to $\pm 20\%$ variation on final assembly. The isolator rubber elements are pre-loaded 5 mm upon assembly.
- Stiffness is linear over working load range.
- Dynamic stiffness may vary with frequency. Values stated are reliable for calculation of low frequency characteristics below 100 Hz.

Typical Installation

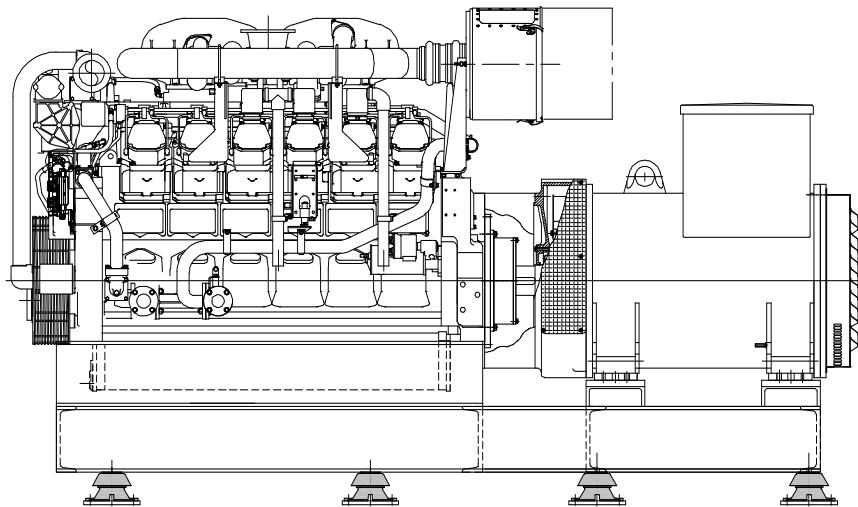

TSC T10 isolators used on a generating set

Application Notes:

- All connections to and from isolated machine must include flexible lengths, not only to prevent transmission of vibration through the connections and allow the system freedom of movement, but also to avoid possible failure of the connections.
- Analysis of the isolated system is normally undertaken by Christie & Grey to predict the response to ship motion, machine forces and shocks to enable the correct selection of flexible connections.

For full installation instructions please refer to our data sheets DS040 and DS060.

For more detailed information and technical assistance please contact our Technical Department.

In the interests of continual development, the Company reserves the right to make modifications to these details without notice.



Christie & Grey Limited

Morley Road, Tonbridge, Kent TN9 1RA, England

Telephone : +44 (0) 1732 371100 • Fax: +44 (0) 1732 359666

E-mail : sales@christiegrey.com • web site: www.christiegrey.com

