

Neoprene Bonded Cork

Type NBC



Neoprene Bonded Cork (NBC) pads are a simple solution to the problem of high frequency noise and vibration produced by many industrial machines.

Pads can be adhered directly to the underside of machine bases or be laid directly onto the floor with minimum preparation of the surface and without the need for grouting or rag bolts.

NBC is made from cork granules bonded into sheets by a neoprene rubber matrix. The combination of these materials provides a high load capacity with resistance to oils, spirits, water and cutting fluids.

DESIGN FEATURES

- Standard sheet size of 1000 mm x 1000 mm available in material thicknesses of 6 mm and 12 mm.
- Multiples of 6 mm and 12 mm are available to special order e.g. 18 mm and 24 mm.
- Also available in 1 m strips with standard widths of 50, 75, 100, 150 and 200 mm.
- Pads or strips can be cut to any size upon request.
- Can be cut to suit on site.
- Rubber Hardness $65 \pm 5^\circ$ IRHD.
- Temperature range -40°C to 100°C .
- Material Density 675 kg/m^3 .

TYPICAL APPLICATIONS

- Air Handling Units.
- Lifts.
- Generators.
- Refrigeration Plant.
- Compressors.
- Pumps.
- Wind Posts and Wall Head Details.

TYPE NBC NEOPRENE BONDED CORK

NBC is rated at up to 830 kN/m² at 2.5 mm deflection for 12 mm thick material and 950 kN/m² at 1.5 mm deflection for the 6 mm thick material, as shown on the load deflection chart below.

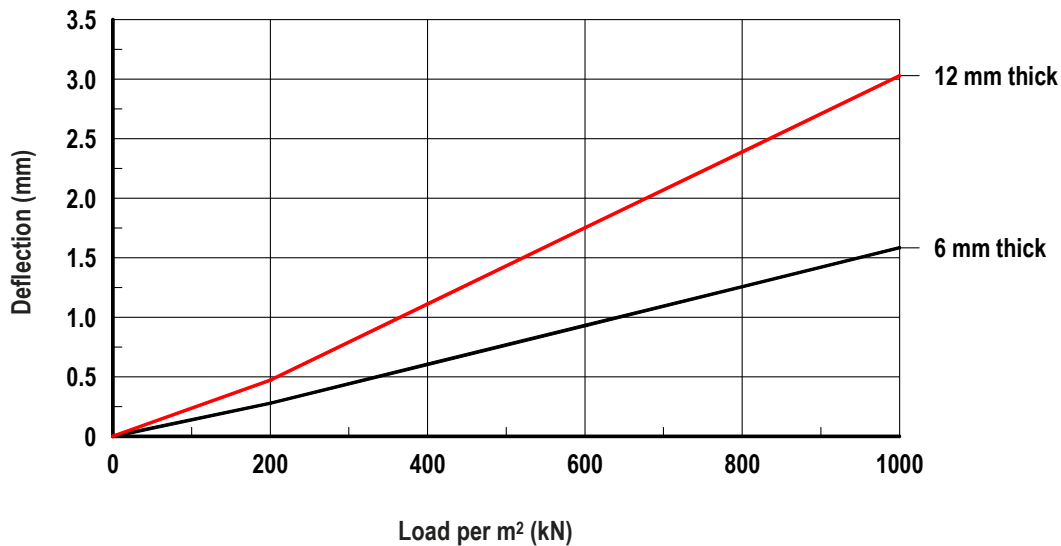

Typical Detail of Steelwork Isolation

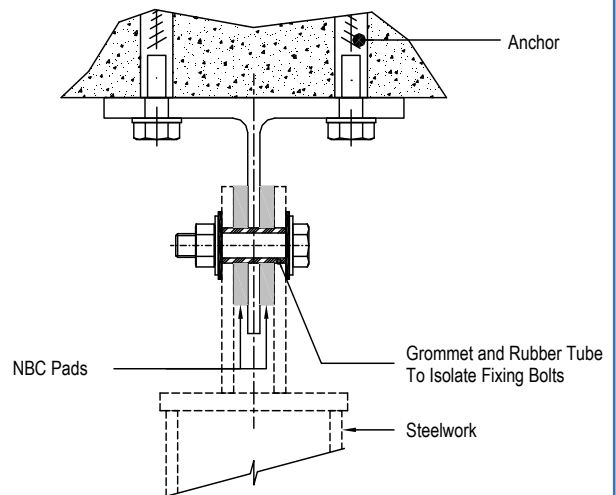
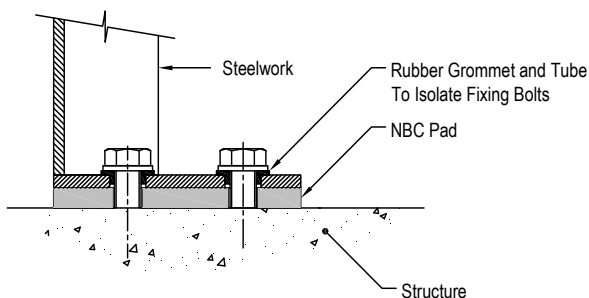

Application Notes:

- Standard sheet size of 1000 mm x 1000 mm with a material thickness of 6 mm and 12 mm. Length and width subject to ± 5 mm tolerance and thickness ± 0.5 mm.
- Also available in 1 m strips with standard widths of 50, 75, 100, 150 and 200 mm.
- Pads or strips can be cut to any size upon request.
- Multiples of 6 mm and 12 mm NBC can be bonded together using contact adhesive and are available to special order e.g. 18 mm and 24 mm thick.
- Neoprene Bonded Cork can be easily installed on any surface. When used in conjunction with a contact adhesive supplied by Christie & Grey, installation costs can be reduced as the need for grouting or rag bolts is eliminated.

For full installation instructions please refer to our data sheet DS031.

For more detailed information and technical assistance please contact our Technical Department.

In the interests of continual development, the Company reserves the right to make modifications to these details without notice.



Christie & Grey Limited

Morley Road, Tonbridge, Kent TN9 1RA, England

Telephone : +44 (0) 1732 371100 • Fax: +44 (0) 1732 359666

E-mail : sales@christiegrey.com • web site: www.christiegrey.com

