

# TECHNICAL DATA SHEET DS 038

NON CONTROLLED UNLESS STATED OTHERWISE

QCF 56 Issue 3

PAGE

1 of 3

ISSUE

7

DATE

6 February 2006

APPROVED

P.J.B

TITLE.

Instructions for Installation of Shock Isolator Type X.

For details of isolator dimensional and stiffness/load characteristics see Leaflet PL021 and Data Sheet No. DS 016.

For details of isolator soleplate for concrete floors see Drawing No. S 077.

Each isolator is made in a range of sizes which are identified by Nominal load, eg 45 kg, stencilled on outer casing.

All isolator metal parts are stainless steel containing a damping compound, with high impact nylon washers for fixing bolts. Soleplates are mild steel with a matt paint finish.

Please consult our application engineers about problem installation areas such as corrosive atmospheres and special paint finish requirements.

Isolators can be installed without the use of soleplates but it is recommended this only be done when isolators are mounted between equipment and steel frame work seating. This should then be carried out using the following procedure;

## A. WITHOUT SOLEPLATES

1. The structure beneath the machines should be constructed to form a rigid and reasonably level seating for each group of isolators. For British Naval applications M.O.D. (N) Shock mount BR3021 should be consulted.
2. The isolators should be examined to ensure they are of the correct size. If appropriate, the positions and orientation for different sizes should be located in accordance with our recommendations or drawings.
3. Bolt the isolators to the underside of the machine base before lowering the machine into position, ensuring that the bolt heads are within isolators - see Figure 1.

Figure 1.

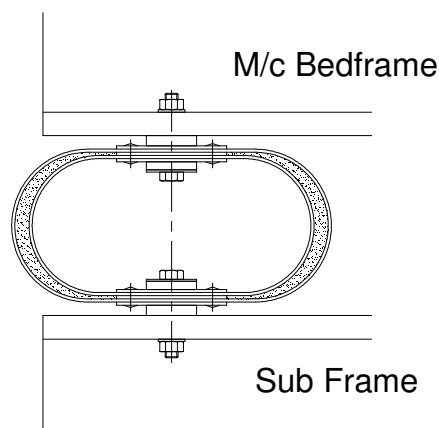

# TECHNICAL DATA SHEET DS 038

NON CONTROLLED UNLESS STATED OTHERWISE

QCF 56 Issue 3

PAGE

2 of 3

ISSUE

7

DATE

6 February 2006

APPROVED

P.J.B

TITLE.

Instructions for Installation of Shock Isolator Type X.

4. Jacks or blocks should be used to support the machine in a level state with a small clearance below each isolator. The clearances must be measured and if they vary by more than 1.0 mm then steel or other rigid packing pieces should be fitted before transferring the machine weight onto the isolators. These packing pieces should be of adequate size.
5. After the equipment weight has been transferred, isolator hold down bolts should be fitted - these must not strain the isolator in any direction. The isolators are not designed to accommodate angular misalignment or variations in level. Note: Fixing bolts/screws are not supplied but it is recommended that high tensile grade 8.8 be used.

Isolators installed on concrete floors must use soleplates - as detailed on Drg No. S077. This should then be carried out using the following procedure:

## B. WITH SOLEPLATES

1. The structure beneath the machines should be constructed to form a rigid and reasonably level seating for each group of isolators.
2. The isolators should be examined to ensure they are of the correct size. If appropriate, the positions and orientation for different sizes should be located in accordance with our recommendations or drawings.
3. Assemble the isolators to the soleplates with a central set screw. This should be well greased to facilitate later removal. Fix the isolators to the machine ensuring that the bolt heads are within the isolators - See Figure 2. Note: Concrete fixings not supplied but it is recommended that high tensile grade 8.8 be used.
4. Support and level the machine to be isolated on solid packing with the soleplates approximately 10 mm clear of the floor.
5. Insert the concrete fixings into the two outer holes in each soleplate leaving sufficient thread beneath the nut to allow for tightening down. Fill the slots in the concrete with grout or resin as required ensuring adequate compaction to remove air and keep the concrete fixings vertical.

# TECHNICAL DATA SHEET DS 038

NON CONTROLLED UNLESS STATED OTHERWISE

QCF 56 Issue 3

PAGE

3 of 3

ISSUE

7

DATE

6 February 2006

APPROVED

P.J.B

TITLE.

Instructions for Installation of Shock Isolator Type X.

Figure 2.

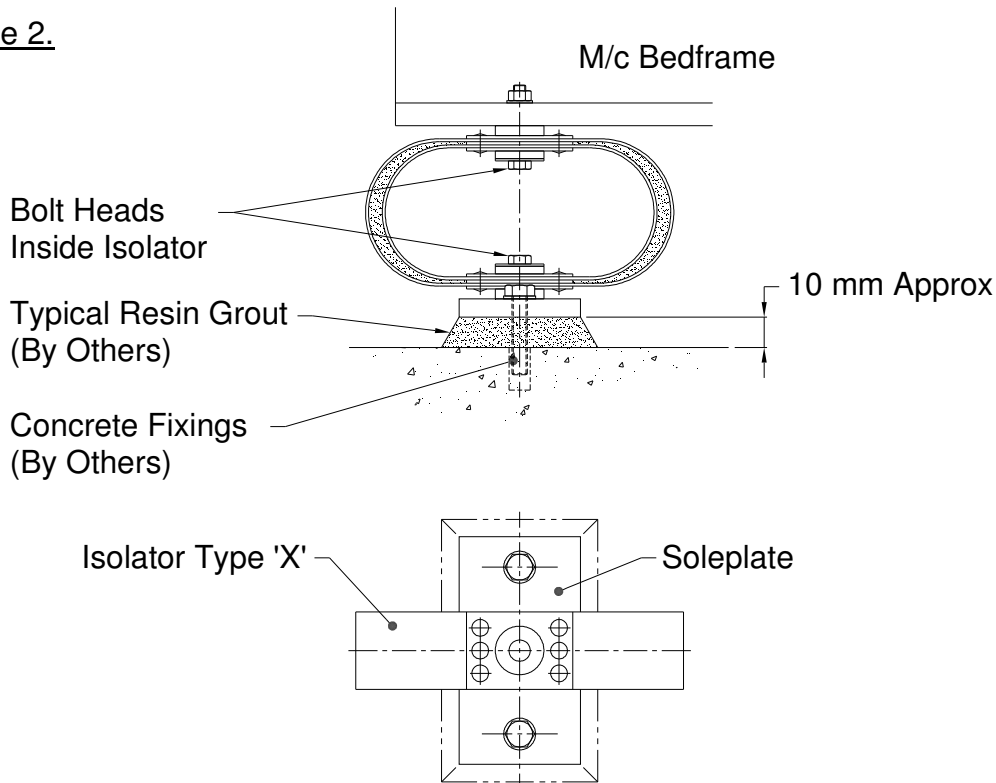

6. After the grout or resin has achieved load bearing strength, the upper fixing screws should be loosened and the machine jacked up just sufficient to remove the solid packing. The machine is then to be lowered onto the isolators which will compress about 7mm. All fixing bolts should then be tightened before connecting services to the machine. (Note: We recommend the use of "Chock-Fast Orange" type resin grout).
7. It is recommended that isolator fixing/HD bolts be tightened to their correct torque values.
8. The efficiency of an isolator system can be seriously impaired if the system is connected to rigid pipes, electrical conduits, ducts or shafts. It is essential that such external connections be as flexible as possible, not only to prevent transmission of vibration through the connections and allow the system freedom of movement, but also to avoid possible failure of the connections.

Please contact our Technical Department at the address below if you have any problems relating to installation or selection.



## Christie & Grey Limited

Morley Road, Tonbridge, Kent TN9 1RA, England

Telephone : +44 (0) 1732 371100 • Fax: +44 (0) 1732 359666

E-mail : sales@christiegrey.com • web site: www.christiegrey.com

