

TECHNICAL DATA SHEET DS 029

NON CONTROLLED UNLESS STATED OTHERWISE

QCF 56 Issue 3

PAGE

1 of 4

ISSUE

6

DATE

6 February 2006

APPROVED

A.N.M

TITLE.

Installation Instructions for SH / RH Hangers.

Details of isolators as Leaflet PL007

Each size of isolator is identified by the colour coded spring or colour coded identification spot.

- 1) Hanger sizes must be selected in accordance with the rated load capacities detailed on our appropriate leaflets.
- 2) Pipes should be supported on either side of changes of direction and additional hangers used to support heavy fittings and vertical droppers.

For larger pipe sizes two hangers can be used at each support position. See Figure 1.

FIGURE 1

SUPPORTING HEAVY VALVES etc.

HEAVY PIPEWORK

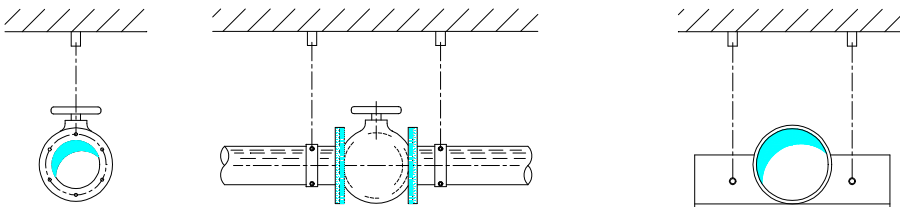

VERTICAL DROPPERS

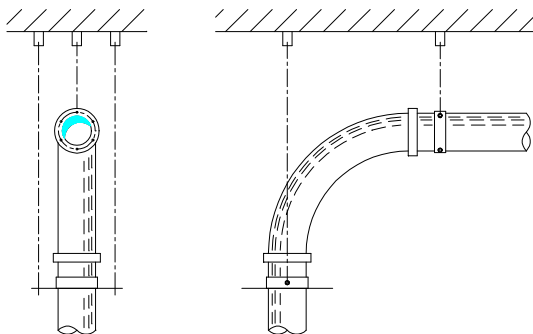

TECHNICAL DATA SHEET DS 029

NON CONTROLLED UNLESS STATED OTHERWISE

PAGE	2 of 4
ISSUE	6
DATE	6 February 2006
APPROVED	A.N.M

TITLE. Installation Instructions for SH / RH Hangers.

- 3) Pipework or equipment must be supported using a solid scaffolding arrangement or hung using wires, ropes or chains in its final position. See Figure 2.
- 4) Spring or rubber hanger brackets should then be securely fixed to upper ceiling or steel gantry at correct spacing to suit hanger load capability.

FIGURE 2

SOLID SCAFFOLDING

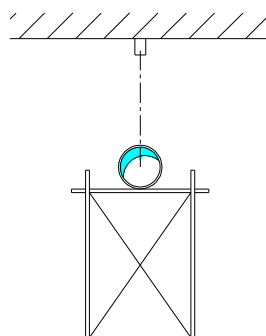
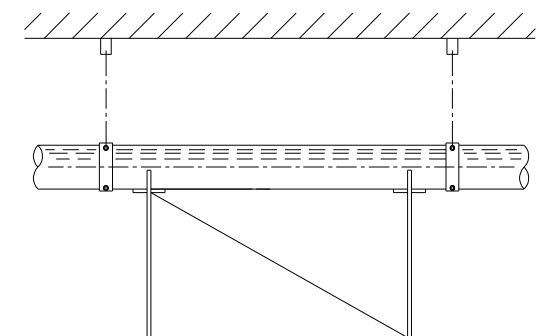

SUPPORTING ROPES, CHAINS OR WIRES

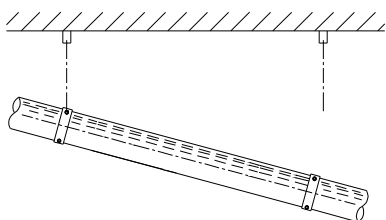
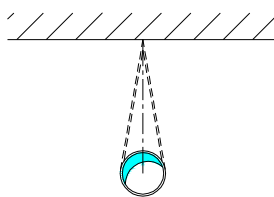
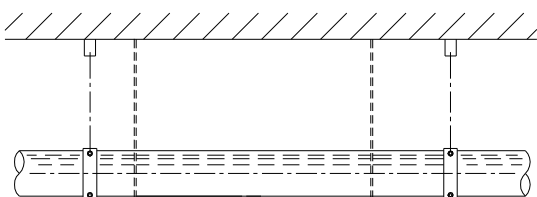

TECHNICAL DATA SHEET DS 029

NON CONTROLLED UNLESS STATED OTHERWISE

PAGE	3 of 4
ISSUE	6
DATE	6 February 2006
APPROVED	A.N.M

TITLE. Installation Instructions for SH / RH Hangers.

- 5) Drop rods should then be cut to size and screwed home into connector coupling on spring hangers or through underside of mount on rubber hangers. See Figure 3.
- 6) Once the pipe/equipment end of the drop rod has been secured, the solid scaffolding or supporting wires can be removed, allowing the weight of pipe work/equipment to be taken by the hangers.

FIGURE 3

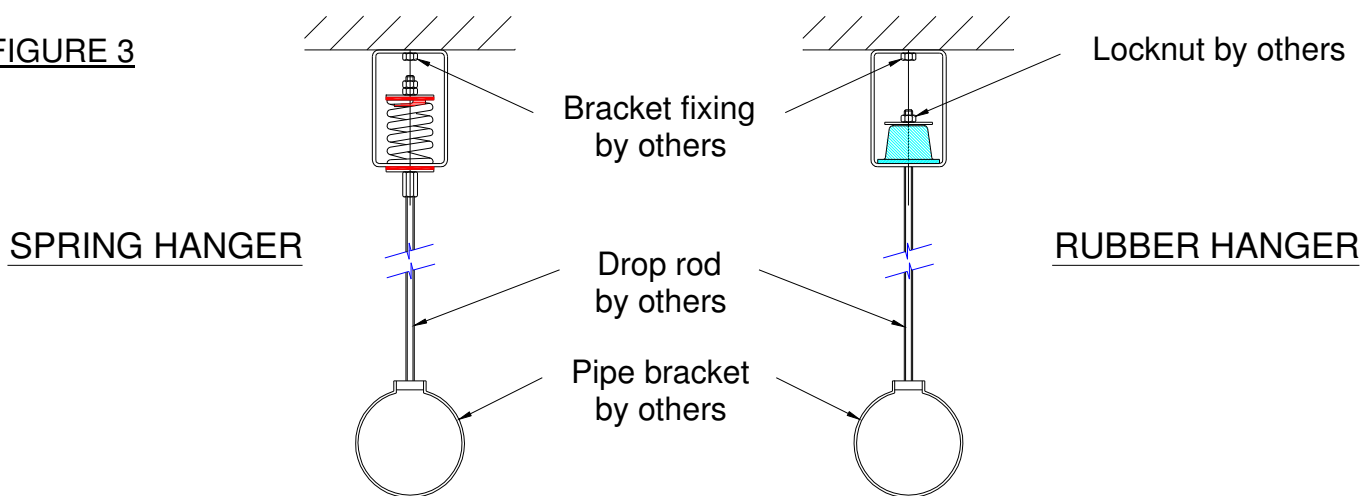

- 7) Depending on the amount of hanger element deflection, either by design or as required by specification, (see our appropriate leaflets) drop rods will require adjustment. This should be done on spring hangers by slackening top locknuts on drop rod inside hanger and then adjusting lower nut until correct height of pipe work requirement is achieved.

It is important that on the spring type hangers a gap of 2 to 3 mm is maintained between the lower washer and underside of frame. See Figure 4.

FIGURE 4

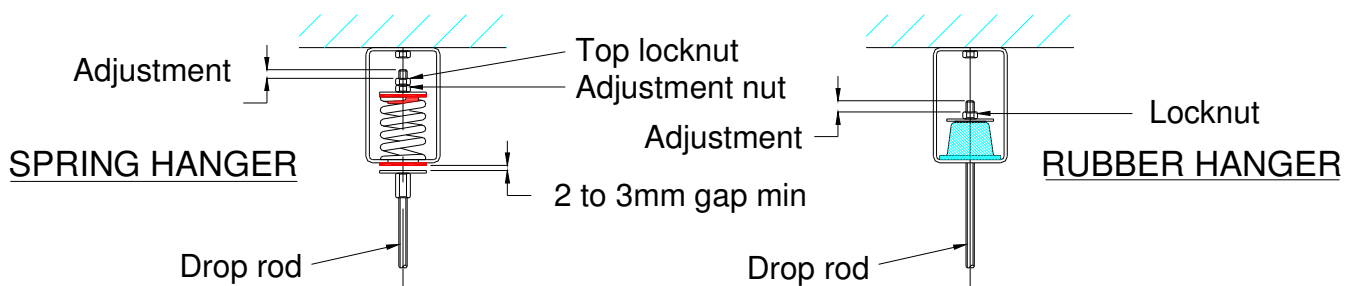

TECHNICAL DATA SHEET DS 029

NON CONTROLLED UNLESS STATED OTHERWISE

QCF 56 Issue 3

PAGE

4 of 4

ISSUE

6

DATE

6 February 2006

APPROVED

A.N.M

TITLE. Installation Instructions for SH / RH Hangers.

Adjustment on rubber hangers should be done by slackening locknut on drop rod inside hanger and then releasing load on element by lifting pipe or equipment and then screwing drop rod further through element.

- 8) If adjustment of spring mounts after installation is not desired or possible, pre compression of springs can be made prior to installation by slackening top locknut and adjusting lower nut until spring is compressed by required amount (max. 25 mm). See Figure 5.
- 9) Hangers can also be fitted into drop rod length as per Figure 6, but care must be taken to ensure misalignment of hanger does not occur.

FIGURE 5

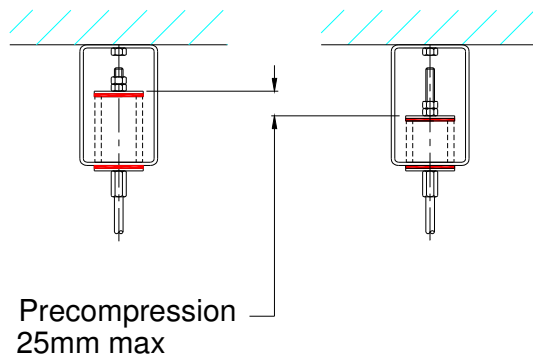
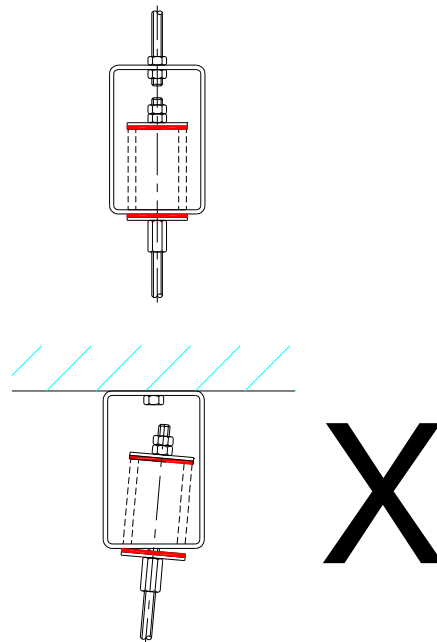

FIGURE 6



- 10) Ensure hangers are not over loaded when installed. Check springs are not coil bound or elements deflected more than limits allowed in our leaflets.

Make sure drop rods are centrally positioned within hanger brackets and are not misaligned. See Figure 7.

FIGURE 7

Note: Surface corrosion is likely without additional protection for external applications.

Please contact our Technical Department at the address below if you have any problems relating to installation or selection.



Christie & Grey Limited

Morley Road, Tonbridge, Kent TN9 1RA, England

Telephone : +44 (0) 1732 371100 • Fax: +44 (0) 1732 359666

E-mail : sales@christiegrey.com • web site: www.christiegrey.com

