

# TECHNICAL DATA SHEET DS 031

NON CONTROLLED UNLESS STATED OTHERWISE

QCF 56 Issue 3

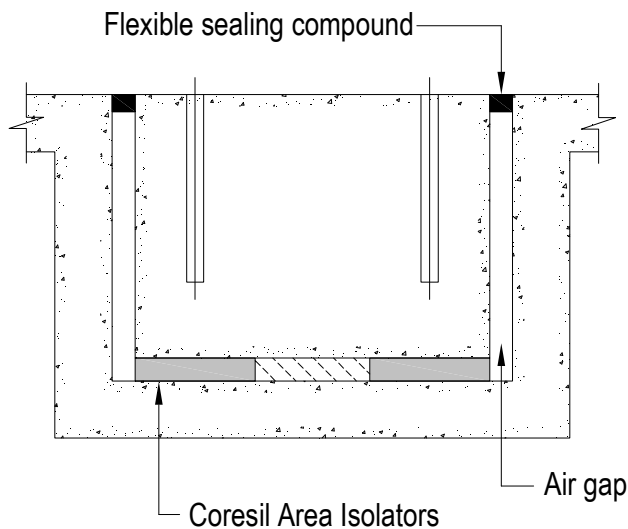
PAGE	1 of 3
ISSUE	6
DATE	6 February 2006
APPROVED	A.N.M

TITLE. Installation of Cork Materials - Coresil, High Density Cork and Resilient Cork Sheets.

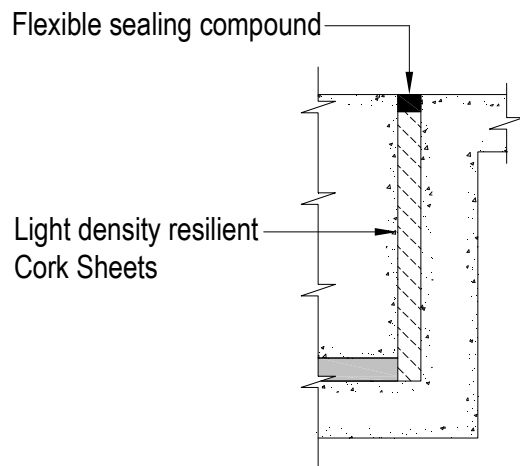
Details of isolators as Leaflet PL026.

- Figure 1** shows a concrete block isolated from a lower concrete raft by Coresil or high density cork sheets. The sides and ends of the block are isolated from the retaining walls of the surrounding pit by an air gap with covers located loosely in rebates at floor level. Alternatively light density resilient cork sheets with a flexible sealing compound at floor level may be used as shown in **Figure 1a**.

**Figure 1**

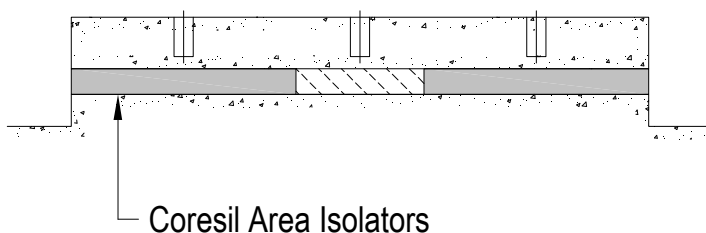


**Figure 1a**

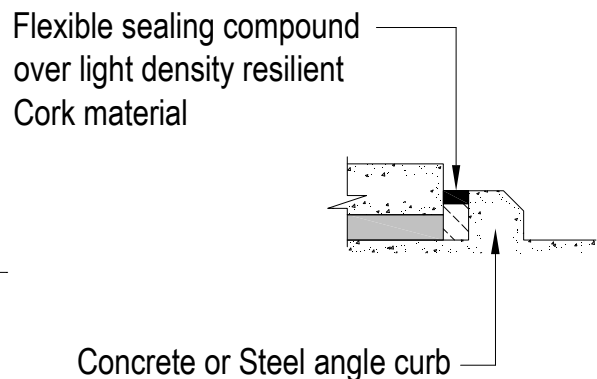


- Figure 2** shows a concrete base isolated by Coresil or high density cork sheets. If required a concrete or steel angle curb is constructed around the base as shown by **Figure 2a**.

**Figure 2**



**Figure 2a**



# TECHNICAL DATA SHEET DS 031

NON CONTROLLED UNLESS STATED OTHERWISE

QCF 56 Issue 3

PAGE

2 of 3

ISSUE

6

DATE

6 February 2006

APPROVED

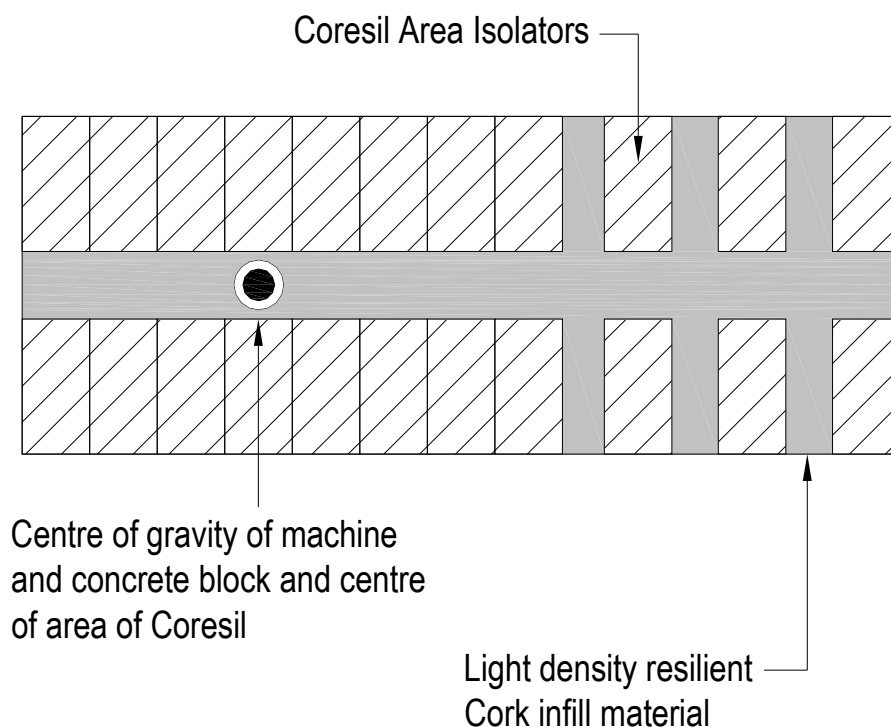
A.N.M

TITLE.

Installation of Cork Materials - Coresil, High Density Cork and Resilient Cork Sheets.

2. **Figure 3** shows a typical arrangement of area isolators beneath a concrete block for a machine. As is often the case, the loading is asymmetric and it is important to obtain equal static deflections and optimum loading on the Coresil. Therefore, the isolators cover only part of the area and are arranged so that their centre of area coincides with the centre of gravity of the machine and block combined. Light density resilient cork material is used over the remainder of the area as an infill to support the concrete. To prevent percolation of the concrete when it is poured a polythene damp proof membrane is supplied to cover all the isolating material. Installation is carried out by our own installation team or by the contractor's labour to our layout drawings and instructions.

**Figure 3.**



3. A typical installation procedure would be carried out as follows:-
- All surface imperfections should be rectified before any works commences. All localised indentations should be filled with Epoxy Grout or similar and any high spots should be removed.
  - The pit floor should be covered with a single layer of the damp proof membrane which must fully cover the floor area. The damp proof membrane should extend up the side and end walls by approximately 100 mm. Any joints should be sealed with waterproof tape.

# TECHNICAL DATA SHEET DS 031

NON CONTROLLED UNLESS STATED OTHERWISE

QCF 56 Issue 3

PAGE

3 of 3

ISSUE

6

DATE

6 February 2006

APPROVED

A.N.M

TITLE.

Installation of Cork Materials - Coresil, High Density Cork and Resilient Cork Sheets.

- iii Adhere the 50 mm thick resilient cork sheets to the pit walls, cutting where necessary and leaving a depth of approximately 20 mm around the top edge. It is not necessary to fully cover the resilient cork sheets with the contact adhesive, just sufficient to ensure adequate adhesion. The bottom edge of the first row of sheets should cover the upturned damp proof membrane. A wooden baton should be used to fill the gap around the top edge which will be removed at a later stage for filling with waterproof flexible sealant.
  - iv The 50 mm thick standard Coresil Area Isolators can now be laid in the position as indicated on our layout drawings and the spaces between them filled with 50 mm thick resilient cork sheets where necessary.
  - v All isolating materials should now be covered with a single layer of the damp proof membrane. Lap and seal all joints with waterproof tape and turn up to top and above side material, corners should be folded in without cutting. This will to ensure that the isolating materials remain dry during pouring of the inertia block.
  - vi Care must be exercised during placement of the steel reinforcement and any damage to the waterproof membrane should be repaired before pouring the concrete.
  - vii All runways and column pits adjacent to the side of foundation must be sealed with bitumen above resilient cork side and end material.
4. The efficiency of an isolator system can be seriously impaired if the system is connected to rigid pipes, electrical conduits, ducts or shafts. It is essential that such external connections be as flexible as possible, not only to prevent transmission of vibration through the connections and allow the system freedom of movement, but also to avoid possible failure of the connections.
5. It is important that no water be allowed to contaminate the area to be isolated during or after installation of cork materials. Pit floor and walls should be dry before installation.

Please contact our Technical Department at the address below if you have any problems relating to installation or selection.



## Christie & Grey Limited

Morley Road, Tonbridge, Kent TN9 1RA, England

Telephone : +44 (0) 1732 371100 • Fax: +44 (0) 1732 359666

E-mail : sales@christiegrey.com • web site: www.christiegrey.com

